

Cahier technique no. 183

Active harmonic conditioners and unity power factor rectifiers

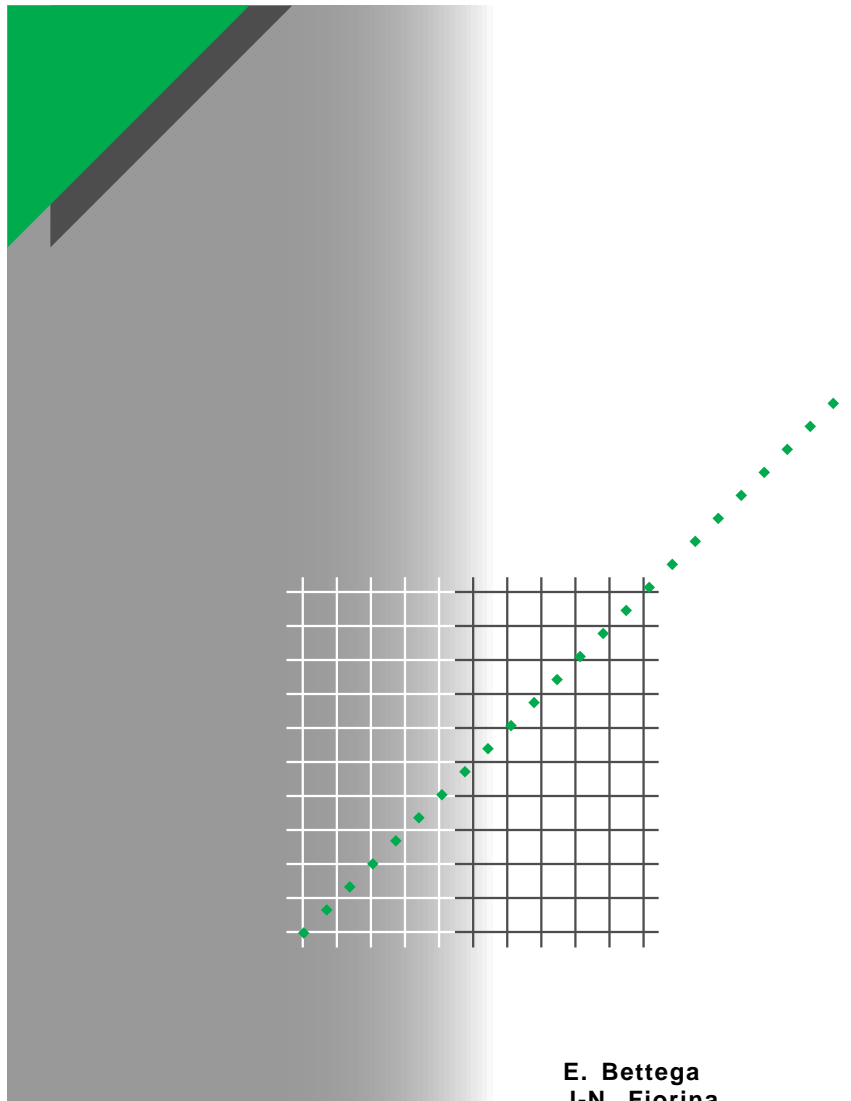

Merlin Gerin

Modicon

Square D

Telemecanique

E. Bettega
J-N. Fiorina

"Cahiers Techniques" is a collection of documents intended for engineers and technicians, people in the industry who are looking for more in-depth information in order to complement that given in product catalogues.

Furthermore, these "Cahiers Techniques" are often considered as helpful "tools" for training courses.

They provide knowledge on new technical and technological developments in the electrotechnical field and electronics. They also provide better understanding of various phenomena observed in electrical installations, systems and equipments.

Each "Cahier Technique" provides an in-depth study of a precise subject in the fields of electrical networks, protection devices, monitoring and control and industrial automation systems.

The latest publications can be downloaded from the Schneider Electric internet web site.

Code: <http://www.schneider-electric.com>

Section: **Experts' place**

Please contact your Schneider Electric representative if you want either a "Cahier Technique" or the list of available titles.

The "Cahiers Techniques" collection is part of the Schneider Electric's "Collection technique".

Foreword

The author disclaims all responsibility subsequent to incorrect use of information or diagrams reproduced in this document, and cannot be held responsible for any errors or oversights, or for the consequences of using information and diagrams contained in this document.

Reproduction of all or part of a "Cahier Technique" is authorised with the prior consent of the Scientific and Technical Division. The statement "Extracted from Schneider Electric "Cahier Technique" no." (please specify) is compulsory.

no. 183

Active harmonic conditioners and unity power factor rectifiers



Eric BETTEGA

After joining Merlin Gerin in 1983 as a laboratory technician in ABT's electronics engineering and design service, he became part of the Scientific and Technical Division in 1986. In 1991 he obtained his Engineering degree from the CNAM (Conservatoire National des Arts et Métiers), and is currently a senior Corporate Research engineer.



Jean Noël FIORINA

He first joined Merlin Gerin in 1968 as a laboratory technician in the ACS (Static Converter Power Supplies) department where he participated in the development of static converters. In 1977 he obtained his ENSERG (Ecole Nationale Supérieure d'Electronique et de Radioélectricité de Grenoble) Engineering degree and rejoined ACS. Starting as development engineer, he was soon afterwards entrusted with projects. He became later responsible for design and development for MGE UPS Systems. He is in some ways the originator of medium and high power inverters.

Active harmonic conditioners and unity power factor rectifiers

Electric loads are becoming increasingly non-linear in the industrial, tertiary and even household sectors. These loads absorb non-sinusoidal currents which, under the effect of circuit impedance, distort the purely sinusoidal voltage waveform. This is what is known as harmonic disturbance of power networks, currently a cause for concern as it gives rise to serious problems.

We recommend that harmonic non-specialist readers begin by reading the appendix where they will find the basic concepts required to understand the various standard and new solutions to limit or combat harmonics. Not only the characteristic quantities, but also the non linear equipment, influence of the sources and disturbing effects of harmonics need to be known. Last but not least, standards lay down levels of compatibility, i.e. the maximum permissible levels.

The purpose of this “Cahier Technique” is to describe the active harmonic conditioners. This attractive, flexible and self-adaptive solution can be used in a wide variety of cases to complete or replace other solutions. However chapter 1 of this “Cahier Technique” will review other “traditional” solutions which should also be taken into consideration.

Contents

1 The traditional solutions	1.1 Reducing harmonic currents of non linear loads	p. 4
	1.2 Lowering harmonic impedance of the source	p. 4
	1.3 Carefully choosing the installation structure	p. 4
	1.4 Harmonic isolation	p. 5
	1.5 Using detuning reactors	p. 5
	1.6 Passive harmonic filters	p. 6
2 Unity PF rectifiers and active harmonic conditioners	2.1 Introduction	p. 7
	2.2 Unity PF rectifiers	p. 8
	2.3 The “shunt type” active harmonic conditioner	p. 11
3 Hybrid active harmonic conditioners	3.1 The “parallel/series” hybrid structure	p. 17
	3.2 The “series/parallel” hybrid structure	p. 18
	3.3 “Parallel” combination of passive filters and active harmonic conditioner	p. 19
	3.4 The performances of hybrid structures	p. 19
4 Implementing a “shunt type” active harmonic conditioner	4.1 Objective and context	p. 22
	4.2 The insertion point of a “shunt-type” active harmonic conditioner	p. 23
	4.3 Sizing a “shunt-type” active harmonic conditioner	p. 24
	4.4 Application examples	p. 25
5 Conclusion		p. 27
Appendix: review of harmonic phenomena	Definition and characteristic quantities	p. 28
	Origin and transmission	p. 29
	Deforming loads	p. 30
	Harmful effects of harmonics	p. 31
	Standard and recommendations	p. 32

1 The traditional solutions

Electricians need to be familiar with these solutions in order to take the right measures when installing polluting equipment or to take all factors into account when designing new installations.

The solutions described hereafter depend on the objective sought and on the non linear/sensitive equipment installed.

They use passive components: reactors, capacitors, transformers and/or carefully choose the installation diagram.

In most cases the aim is to reduce voltage total harmonic distortion at a load multi-connection point (in a distribution switchboard).

1.1 Reducing harmonic currents of non linear loads

Besides the obvious solution which consists of choosing non-disturbing equipment, the harmonic currents of some converters can be limited by inserting a **“smoothing” reactor** between their connection point and their input. This solution is particularly employed with rectifiers with front end capacitors: the reactor

may even be proposed as an option by manufacturers.

A word of warning however! Although this solution reduces voltage total harmonic distortion upstream of the reactor, it increases it at the terminals of the non-linear load.

1.2 Lowering harmonic impedance of the source

In concrete terms this consists of connecting the disturbing equipment directly to the most powerful transformer possible, or of choosing a generator with a low harmonic impedance (see appendix and **fig. 1**).

Note that it is advantageous on the source side to use several parallel-connected cables of smaller cross-section rather than a single cable. If these conductors are far enough apart, apparent source impedance is divided by the number of parallel-connected cables.

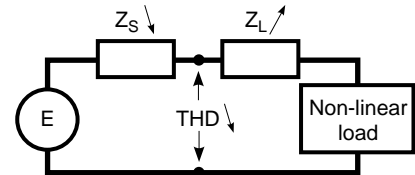

Fig. 1: addition of a downstream reactor or reduction in upstream source impedance reduces voltage THD at the point considered.

1.3 Carefully choosing the installation structure

Sensitive loads should not be parallel-connected with non-linear loads (see **fig. 2**).

Very powerful non-linear loads should preferably be supplied by another MV/LV transformer.

a) Solution to avoid

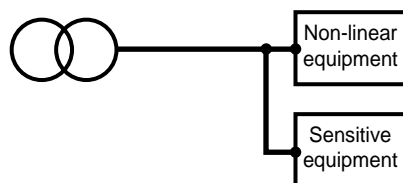

b) Solution to recommended

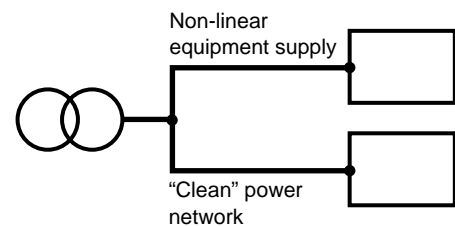

Fig. 2: a Y-shaped distribution enables decoupling by natural and/or additional impedances.

1.4 Harmonic isolation

The aim is to limit circulation of harmonic currents to as small a part as possible of the installation **using suitable coupling transformers**.

Use of Y-connected primary transformers (without neutral!) with zig-zag secondary is an interesting solution as it ensures minimum distortion at the secondary. In this case $3k$ order harmonic currents do not flow at the transformer primary, and the impedance Z_s depends only on the secondary windings. The inductive part of the impedance is very low:

$U_{ccx} \approx 1\%$, and resistance is practically halved compared with a ΔY transformer of identical power.

Figure 3 and the following calculation show why $3k\omega$ angular frequencies are not present at the transformer primary (zero sequence current is nil).

Current circulating for example in the primary winding 1 equals:

$$\frac{N_2}{N_1} (i_1 - i_2)$$

where

$$i_1 = I_{1(3k)} = I \sin(3k\omega t)$$

$$i_3 = I_{3(3k)} = I \sin 3k \left(\omega t - \frac{4\pi}{3} \right)$$

$$i_3 = I \sin(3k\omega t) = i_1$$

hence

$$\frac{N_2}{N_1} (i_1 - i_3) = 0$$

As regards three-phase loads, some harmonic orders can be removed by using transformers or autotransformers with a number of displaced secondaries, a solution particularly adopted for powerful rectifiers. The best known of these circuit assemblies is the rectifier consisting of two serial or parallel-connected bridges, supplied by a transformer with two secondaries, one Y and the other delta connected. This assembly produces a 30 degree phase displacement between the voltages of the two secondaries.

The calculation shows that the $6k \pm 1$ order harmonics where k is odd are removed from the transformer primary. The first harmonics removed, which are also the highest in amplitude, are for $k = 1$, harmonics 5 and 7. The first harmonics present are then 11 and 13.

This property can be generalised by increasing the number of rectifiers and the number of transformer secondaries or the number of transformers by choosing the appropriate phase displacement for each secondary.

This solution is commonly employed in the case of very high power rectifiers where current distribution in the various bridges presents no problems. It is frequently used by electrolytic rectifiers (up to 72 phases!).

Parallel-connected uninterruptible power supplies (UPS) are of special interest, as the inverters share the output currents and the rectifiers supplying them absorb identical currents.

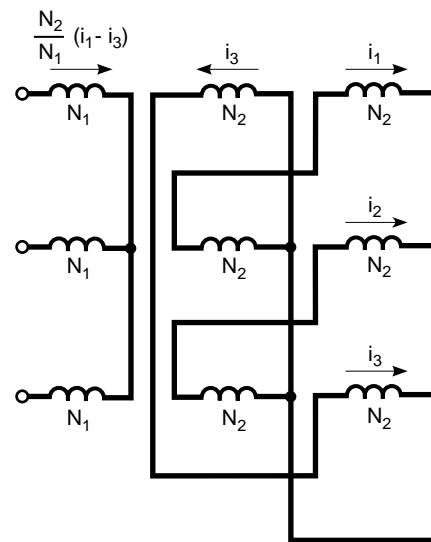

Fig. 3: zig-zag secondary transformer and attenuation of $3k$ order harmonics.

1.5 Using detuning reactors

This solution consists of protecting the capacitors, designed to improve the displacement power factor by installing a series reactor.

This reactor is calculated so that resonance frequency matches none of the harmonics present.

Typical tuning frequencies are for a 50 Hz fundamental: 135 Hz (order 2.7), 190 Hz (order 3.8) and 255 Hz (order 4.5).

Thus for the fundamental, the battery can perform its displacement power factor improvement function, while the high impedance of the reactor limits amplitude of the harmonic currents.

The switched-steps capacitors must allow for the priority of certain resonance frequencies.

1.6 Passive harmonic filters

This case differs from the above in that a capacitor is used in series with a reactor in order to obtain tuning on a harmonic of a given frequency. This assembly placed in parallel on the installation has a very low impedance for its tuning frequency, and acts as a short-circuit for the harmonic in question.

A number of assemblies tuned on different frequencies can be used simultaneously in order to remove several harmonic orders.

Passive filters contribute to reactive energy compensation of the installation.

This apparently simple principle nevertheless calls for thorough study of the installation since, although the filter acts as a short-circuit for the required frequency, there is a possibility of resonance risks with other power network reactors on other frequencies and thus of increased previously non-troublesome harmonic levels prior to its installation (see "Cahier Technique" no. 152).

2 Unity PF rectifiers and active harmonic conditioners

2.1 Introduction

The previous chapter reviewed the techniques and corresponding passive systems used to reduce harmonic disturbances.

These systems all modify impedances, impedance ratios or cause the opposition of certain harmonic currents.

Other impedance monitoring means are available (which we shall not dare to term “intelligent”!), which use static converters of ever increasing effectiveness due to the steady increase in semiconductor power component possibilities (see table [fig. 4](#)).

IGBT’s made possible the industrial development of power converters able to guarantee non-disturbance at the point of common coupling (unity power factor rectification), and harmonic compensation of power networks (active harmonic compensation).

■ Unity PF rectification is a technique enabling static converters to absorb a current very similar to a sinusoidal waveform with, in addition, a displacement power factor close to the unit: this highly interesting technique should be used with increasing frequency.

■ Active harmonic compensation

An active harmonic conditioner is a device using at least one static converter to meet the “harmonic compensation” function.

This generic term thus actually covers a wide range of systems, distinguished by:

- the number of converters used and their association mode,
- their type (voltage source, current source),
- the global control modes (current or voltage compensation),
- possible association with passive components (or even passive filters).

The only common feature between these active systems is that they all generate currents or voltages which oppose the harmonics created by non-linear loads. The most instinctive achievement is the one shown in [figure 5](#) which is normally known as “shunt” (or “parallel”) topology.

It will be studied in detail in paragraph 3.

The “serial” type active harmonic conditioner (see [fig. 6](#)) will be mentioned merely as a

Technology		V	A	F (kHz)
Transistor	MOS	500	50	50
	Bipolar	1,200	600	2
	IGBT	1,200	600	10
Thyristor	GTO	4,500	2,500	1

Fig. 4: typical characteristics of use of power semiconductors in static converters.

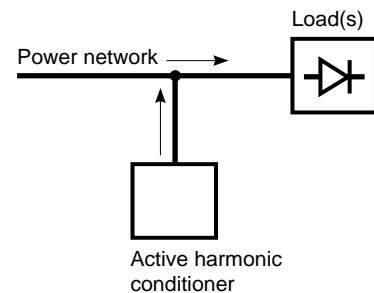

Fig. 5: “shunt-type” active harmonic conditioner generates an harmonic current which cancels current harmonics on the power network side.

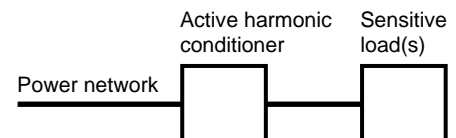

Fig. 6: “series type” active harmonic conditioner generates an harmonic voltage which guarantees a sinusoidal voltage on the load terminals.

reminder as it is seldom used. Its function is to enable connection of a sensitive load on a disturbed power network by blocking the upstream harmonic voltage sources. However, in actual practice, this “upstream” harmonic compensation technique is of little interest since:

- the “quality” of the energy at the point of common coupling is satisfactory in the majority of cases,
- insertion of a component in the “serial” mode is not easy (for example short-circuit current withstand),
- it is more useful to examine the actual causes of voltage distortion within a power network (the harmonic current sources).

Out of the numerous “hybrid” alternatives we shall concentrate on the “serial/parallel” type combining active and passive filtering (see **fig. 7**) which is a very effective solution for harmonic cancellation close to high power converters.

However this “Cahier Technique” does not aim to be comprehensive and deliberately chooses not to treat many topologies. This is because all the other systems are merely variations on a same theme and because the basic solutions are described in this document.

Before going on to describe unity PF rectifiers and active harmonic conditioners in detail, it should be noted that there is a certain technological resemblance between these two devices, namely:

- when the control strategy of a rectifier bridge (integrating, for example, a BOOST stage) imposes circulation of a current reduced merely to its fundamental, **this is called unity PF rectification** and the rectifier is said to be “clean”,
- when the current reference applied to this control is (for example) equal to the harmonic content of the current absorbed by a third-party non linear load, the rectifier cancels all the harmonics at the point of common coupling: **this**

2.2 Unity PF rectifiers

Whether for rectifiers, battery chargers, variable speed drives for DC motors or frequency converters, the device directly connected with the power network is always a “rectifier”. This component, and more generally the input stage (power and control) determines the harmonic behaviour of the complete system.

Unity PF rectification principle (in single-phase)

This consists of forcing the absorbed current to be sinusoidal. Unity PF rectifiers normally use the PWM (Pulse Width Modulation) switching technique. Two main categories are identified according to whether the rectifier acts as a voltage source (most common case) or a current source.

- Voltage source converter
In this case the converter acts as a back-electromotive force (a “sinusoidal voltage

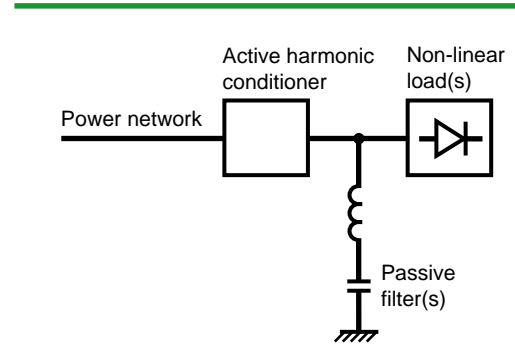

Fig. 7: “series/parallel” type hybrid filter.

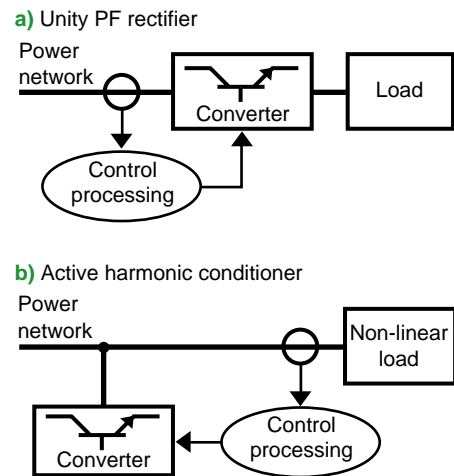

Fig. 8: unity PF rectifier and active harmonic conditioner.

is known as active harmonic conditioner. Thus the same power topology is able to meet the two separate needs which are non-disturbance and harmonic compensation. Only the control strategy differs (see **fig. 8**).

generator”) on the power network (see **fig. 9**), and the sinusoidal current is obtained by inserting a reactor between the power network and the voltage source.

Voltage is modulated by means of a control loop designed to maintain current as close as possible to the required sinusoidal voltage waveform.

Even if other non-linear loads raise the power network’s voltage total harmonic distortion, regulation can be used to draw a sinusoidal current.

The frequency of low residual harmonic currents is the frequency of modulation and of its multiples. Frequency depends on the possibilities of the semiconductors used (see **fig. 4**).

■ **Current source converter**

This converter acts as a chopped current “generator”. A fairly large passive filter is required to restore a sinusoidal current on the mains side (see **fig. 10**). This type of converter is used in specific applications, for example to supply an extremely well regulated DC current.

“**Voltage converter**” implementation principle

Its ease of implementation means that the diagram in **figure 11** is the one most often chosen (as for certain MGE UPS systems). This diagram uses the voltage generator principle.

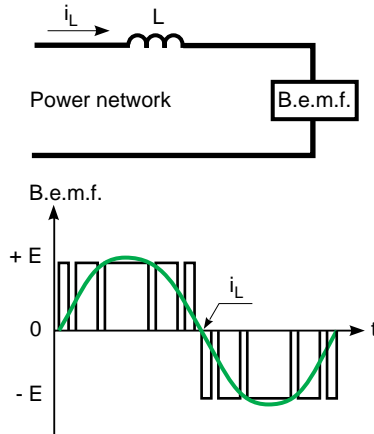

Fig. 9: single-phase diagram equivalent to a voltage PWM converter.

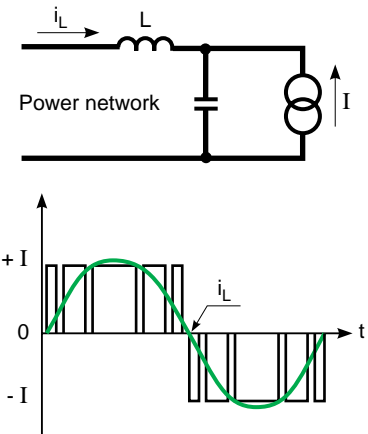
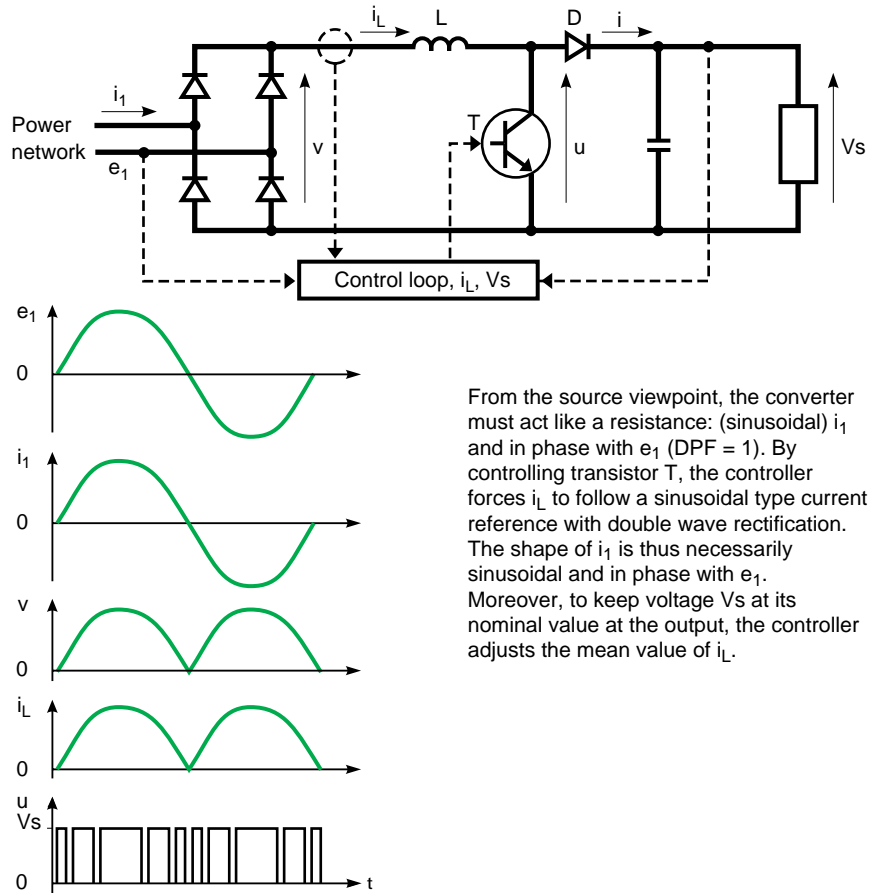

Fig. 10: single-phase diagram equivalent to a current PWM rectifier.



From the source viewpoint, the converter must act like a resistance: (sinusoidal) i_1 and in phase with e_1 (DPF = 1). By controlling transistor T, the controller forces i_L to follow a sinusoidal type current reference with double wave rectification. The shape of i_1 is thus necessarily sinusoidal and in phase with e_1 . Moreover, to keep voltage V_s at its nominal value at the output, the controller adjusts the mean value of i_L .

Fig. 11: single-phase diagram equivalent to a current PWM rectifier.

Transistor T (normally using MOS technology) and diode D make up the voltage modulator. The voltage (u) thus moves from 0 to V_s according to whether transistor T is in the on or off state. When transistor T is conductive, the current in reactor L can only increase as voltage v is positive and $u = 0$.

The relationship is then:

$$\frac{di}{dt} = \frac{e}{L} > 0.$$

When transistor T is off, the current in L decreases, provided that V_s is greater than v, so that:

$$\frac{di}{dt} = \frac{e - V_s}{L} < 0.$$

For this condition to be fulfilled, voltage V_s must be greater than the peak voltage of v, i.e. the rms value of the ac voltage, multiplied by $\sqrt{2}$. If this condition is fulfilled, the current in L can be increased or decreased at any time. The time evolution of current in L can be forced by monitoring the respective on and off times of transistor T.

Figure 12 shows the evolution of current i_L with respect to a reference value.

The closer are the switching moments of T (i.e. switching frequency is high), the smaller the errors of i_L compared with the reference sine wave will be. In this case the current i_L is very close to the rectified sinusoidal current, and the line current i_1 is necessarily sinusoidal.

Figure 13 shows the time curve and the harmonic spectrum of the current drawn by a unity PF rectifier of a 2.5 kVA UPS. In this case the transistor is a MOS, and the switching frequency equals 20 kHz.

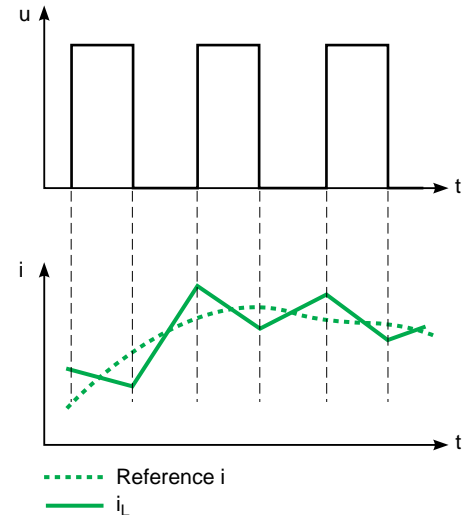
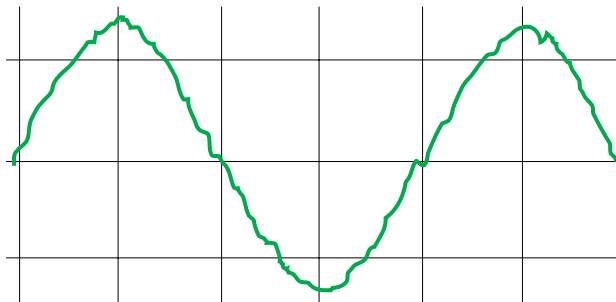

Fig. 12: evolution of current i_L compared with the reference i .

a) Time form



b) Spectral breakdown

Order	Max. contrib. as a% of I1 as in IEC 1000-3-2	Typical values without unity PF rectifier ($U_{ccx} = 1\%$)	Measured value
3	14.65%	81%	8.03%
5	7.26%	52%	2.94%
7	4.90%	24%	3.15%
9	2.55%	6%	1.65%
11	2.10%	7%	1.09%
13	1.34%	6%	1.07%

Fig. 13: current upstream of a "clean" single-phase rectifier (2.5 kVA UPS - PULSAR-PSX type).

The harmonics of the current absorbed are highly attenuated compared with a switch mode power supply which does not use the “unity PF rectification” control strategy, and their level is below standard requirements. Filtering of ≥ 20 kHz orders is easy and inexpensive.

Three-phase circuits

The basic circuit arrangement is shown in **figure 14**.

We recognise the arrangement in figure 11 with reactors placed upstream of the rectifiers. The operating principle is the same. The monitoring system controls each power arm, and forces the current absorbed on each phase to follow the sinusoidal reference. There are currently no three-phase unity PF rectifiers on the market as additional cost is high. Changes in standards may however stipulate their use.

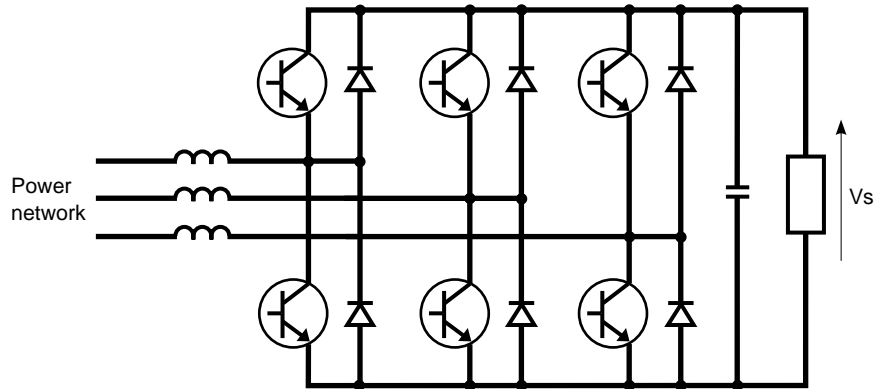

Fig. 14: single-phase diagram equivalent to a current PWM rectifier.

2.3 The “shunt-type” active harmonic conditioner

Operating principle

The «shunt-type» active harmonic conditioner concept can be illustrated by means of an electro-acoustic analogy (see **fig. 15**). The observer will no longer hear the noise source S if a secondary noise source S' generates a

counter-noise. The pressure waves generated by the loudspeaker have the same amplitude and are in opposition of phases with those of the source: this is the destructive interference phenomenon. This technique is known as ANR (Active Noise Reduction).

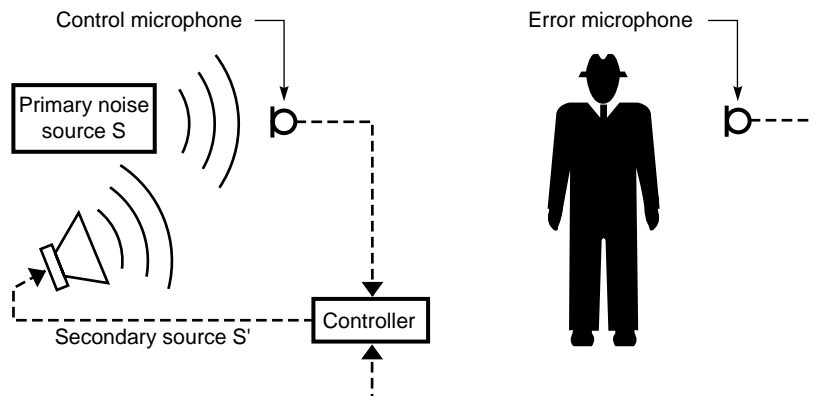

Fig. 15: single-phase diagram equivalent to a current PWM rectifier.

This analogy is a perfect illustration of the “shunt-type” active harmonic conditioner: the aim is to limit or even remove the current (or voltage) harmonics at the point of common coupling by injecting an appropriate current (or voltage) (see **fig. 16**).

Provided that the device is able to inject **at any time** a current where each harmonic current has the same amplitude as that of the current in the load and is in opposition of phases, then Kirchoff’s law at point A guarantees that the current supplied by the source is purely sinusoidal. The combination of “non linear loads + active harmonic conditioner” forms a linear load (in which current and voltage are linked by a factor k). This kind of device is particularly suited for harmonic compensation of LV networks irrespective of the chosen point of coupling and of the type of load (the device is self-adaptive).

The following functions are thus performed according to the level of insertion:

- local harmonics compensation: if the active harmonic conditioner is associated with a single non linear load,
- global harmonics compensation: if the connection is made (for example) in the MLVS (Main Low Voltage Switchboard) of the installation.

The “shunt-type” active harmonic conditioner thus forms a current source independent of

power network impedance, and with the following intrinsic characteristics:

- its band-width is sufficient to guarantee removal of most harmonic components (in statistical terms) from the load current. We normally consider the range $H_2 - H_{23}$ to be satisfactory, as the higher the order, the lower the harmonic level.
- its response time is such that harmonic compensation is effective not only in steady state but also in “slow” transient state (a few dozen ms),
- its power enables the set harmonic compensation objectives to be met. However this does not necessarily mean total, permanent compensation of the harmonics generated by the loads.

Provided that these three objectives are simultaneously achieved, the “shunt-type” active harmonic conditioner forms an excellent solution as it is self-adaptive and there is no risk of interaction with power network impedance. It should also be noted that the primary aim of this device is not to rephase the fundamental U and I components: insertion of an active harmonic conditioner has no effect on the displacement power factor.

Nevertheless, if the load treated is of the “multiphase rectifier” kind, then the global power factor is indeed considerably improved as the distortion factor is closer to the unit and the

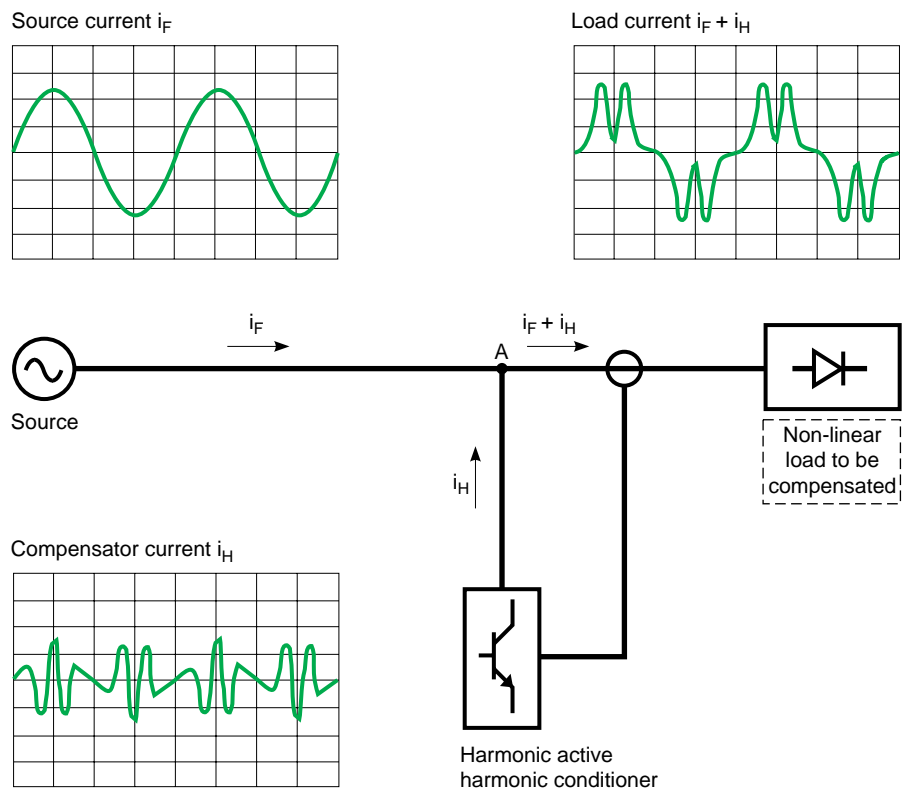

Fig. 16: principle of compensation of harmonic components by “shunt-type” active harmonic conditioner.

displacement power factor of a rectifier (not controlled) is close to the unit. However this is more a “secondary effect” than an actual objective!

Although the main purpose of the device is harmonic depollution, it can also compensate power factor. In that case the reactive current may be proportionally high and should be accounted for in the product current rating.

Structure of the “shunt-type” active harmonic conditioner

This device is broken down into the following two subassemblies (see fig. 17).

- Power: input filter, reversible inverter, storage components,
- Control: reference processing, U/I controls, converter low level control.

The main difference between a converter and a unity PF rectifier, described in the previous chapter, lies in the control and monitoring (as the setpoint is no longer a 50 Hz sine wave). If the “storage” component is a capacitor or battery, the converter has a similar structure to that of the

input stage of the converter with unity PF rectifier (see fig. 18).

A reactor can also be used (see fig. 19).

MGE UPS Systems chose Voltage Source Inverter -VSI- for its SINEWAVE range because

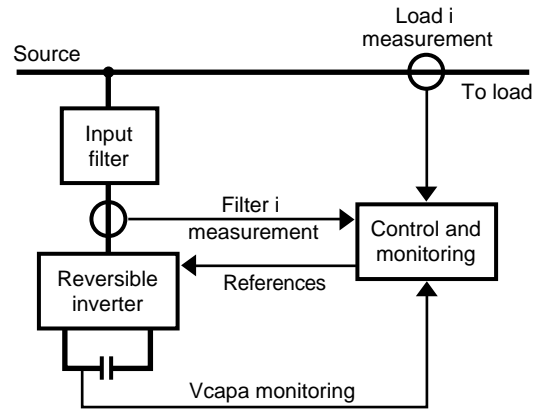

Fig. 17: schematic diagram showing the structure of the “shunt-type” active harmonic conditioner.

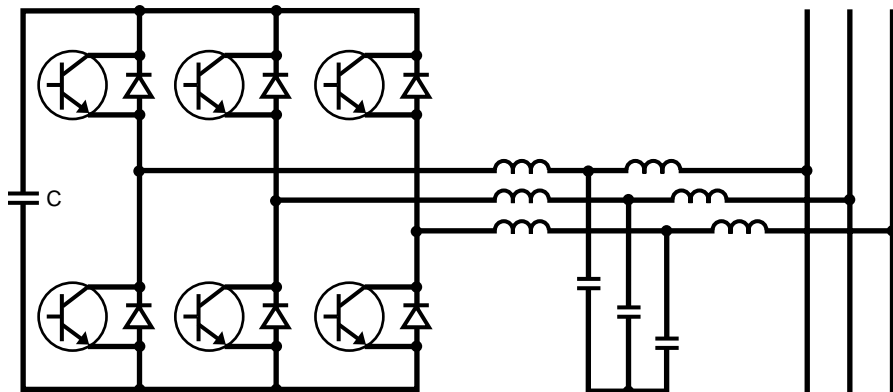

Fig. 18: diagram showing the “shunt type” active harmonic conditioner with VSI (voltage source inverter).

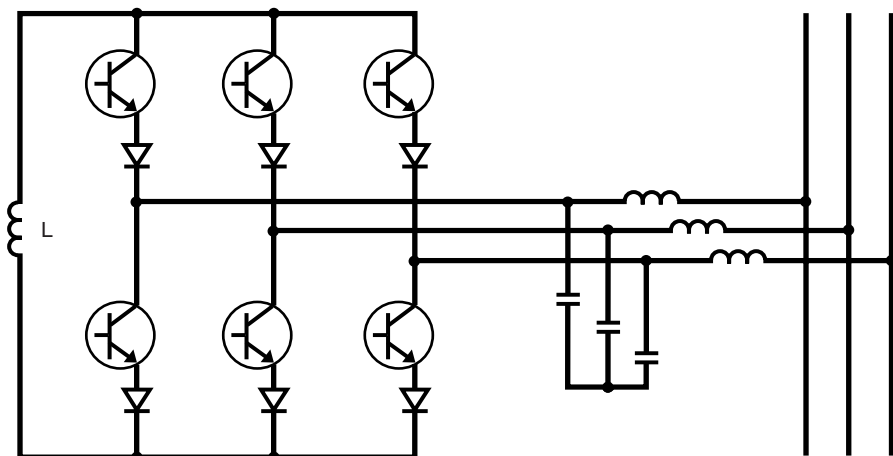

Fig. 19: diagram showing the “shunt type” active harmonic conditioner with CSI (current source inverter).

of its added value in technical and economic terms: wider pass-band, simpler input filter. Moreover the VSI structure technically resembles inverter structure.

Control and monitoring electronics

Its main function is to control the power semiconductors. As such it must:

- control capacitor load (c) on energising,
- regulate voltage at the terminals of c,
- c generate “rectifier” on/off patterns when it has an inverter function so that the active harmonic conditioner permanently supplies a current compensating the non linear harmonic currents (see fig. 16).

There are 2 signal processing methods, namely:

- the real time method, which is particularly suitable for loads with ultra-fast variations in their harmonic spectrum. It can use the “synchronous detection” method or use Clark transformations;

- the non real time method, used for loads where the harmonic content of the current absorbed varies slightly in 0.1 s. This method uses the frequency analysis principle and is based on the Fast Fourier Transform (FFT). It enables global or selective treatment of harmonic orders.

Examples of performances obtained using non-linear loads

In these examples the loads do not operate on full load, as the THD (I) is at its lowest on full load. In the example below, the THD (I) is 30% on full load, whereas it is 80% with a 20% load.

■ Case of a UPS

A “shunt-type” active harmonic conditioner is parallel-connected on a three-phase uninterruptible power supply of a power of 120 kVA. The current time waveforms are shown in **figure 20**. The spectrum of the current absorbed by the load is given in **figure 21** and corresponds to an

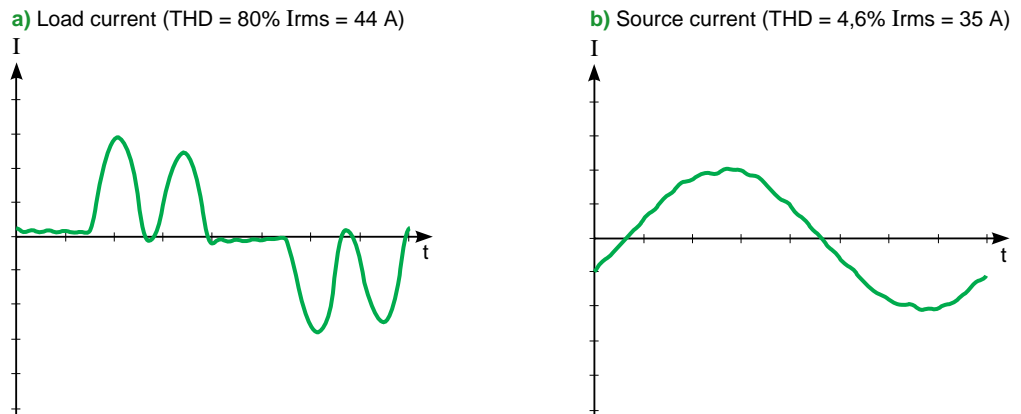

Fig. 20: “shunt-type” active harmonic conditioner associated with a UPS - time waveforms of currents (20% load).

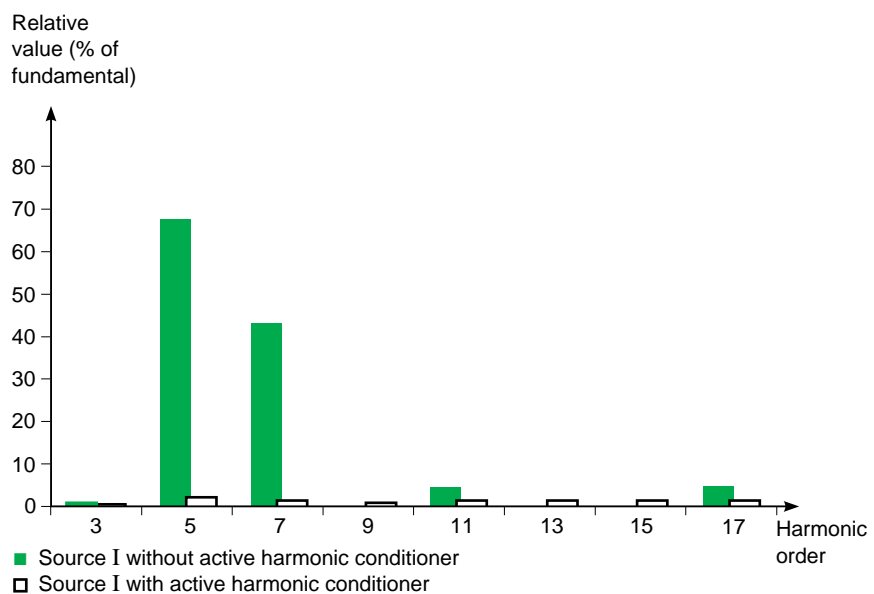

Fig. 21: “shunt type” active harmonic conditioner on UPS - source currents spectrum.

harmonic distortion of 80%. Use of the “shunt type” active harmonic conditioner considerably attenuates the THD (I) which drops from 80% to 4.6%. The rms current drops by nearly 20%, and the power factor increases by 30% (see fig. 21 and 22).

■ Case of a VSD (frequency converter type)
An active harmonic conditioner is parallel-

connected to a variable speed drive for asynchronous motor of a power of 37 kW operating on half-load. The current time waveforms are shown in figure 23 and correspond to an harmonic distortion of 163% for the load current.

Figure 24 shows the harmonic spectrum of the source and load currents.

Current characteristics	Without active harmonic conditioner	With active harmonic conditioner
Irms (A)	44.1	35.2
Peak factor	1.96	1.52
THD (I) as a %	80.8	4.6
Power factor	0.65	0.86
DPF	0.84	0.86
Harmonic Irms (A)	27.7	1.6

Fig. 22: “shunt-type” active harmonic conditioner on UPS: measured values.

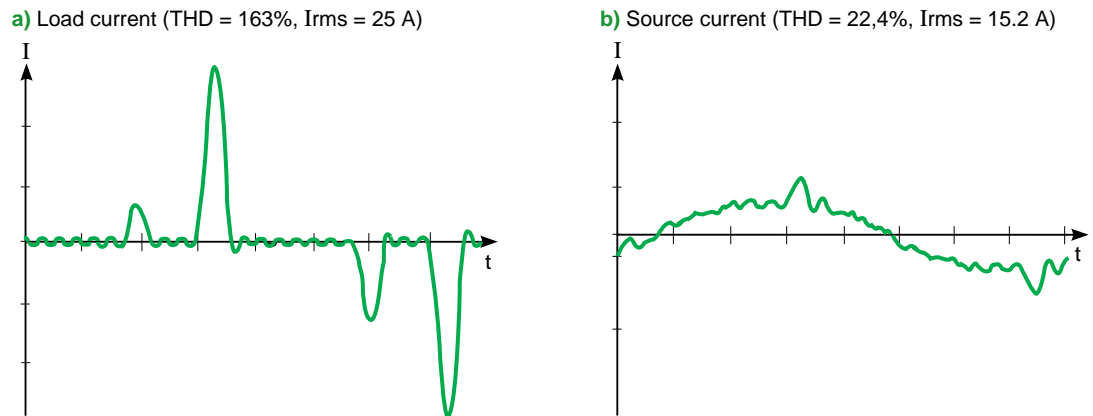

Fig. 23: “shunt-type” active harmonic conditioner on variable speed drive - waveforms of currents on half-load.

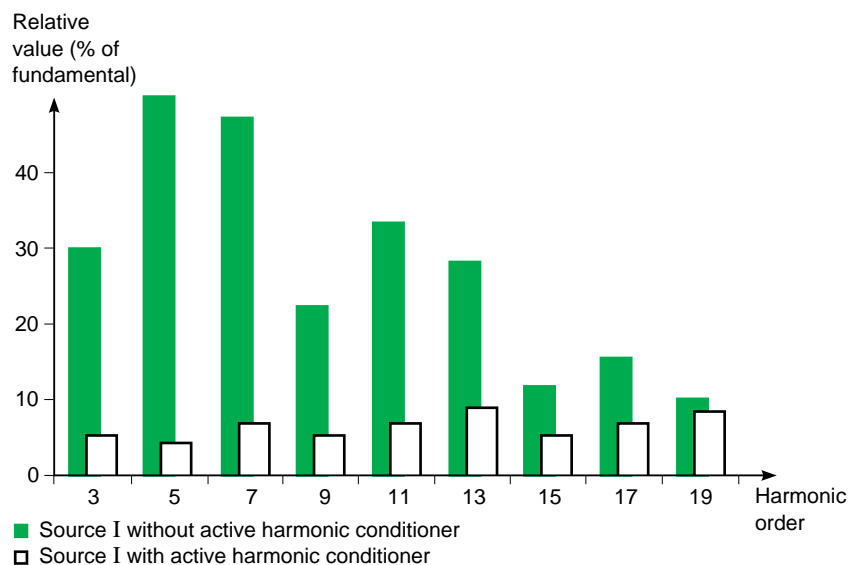

Fig. 24: “shunt-type” active harmonic conditioner associated with a variable speed drive - harmonic spectrum of the source current.

Use of the “shunt-type” active harmonic conditioner considerably attenuates the THD (I) which drops to 22.4%. The rms current drops by nearly 40% (see [fig. 24](#) and [25](#)). Performance is lower than in the first case (UPS) since line current fluctuations are much faster. In this cases addition of a 0.3 mH smoothing reactor is recommended. The table in [figure 26](#) illustrates the resulting increase in effectiveness. We can conclude that the “shunt type” active harmonic conditioner is an excellent means for removing harmonics on a feeder or non-linear load. However:

- removal of all disturbances, even if it is possible, is not necessarily the aim,
- it is not suited to voltage power networks exceeding 500 V,
- it has no effect on disturbances upstream of the current sensor,
- technical and economic considerations may require use combined with a passive component; for example a reactor (see [fig. 26](#)) or a passive filter to remove the 3rd or 5th harmonic (considerable decrease in “shunt type” active harmonic conditioner power rating).

Characteristics of current on half-load	Without active harmonic conditioner	With active harmonic conditioner
Irms (A)	25.9	15.2
Peak factor	3.78	1.95
THD (I) as a %	163	22.4
Harmonic Irms (A)	21.7	3.3

Fig. 25: “shunt-type” active harmonic conditioner associated with a variable speed drive - current characteristics.

Characteristics of current on full load	With active harmonic conditioner and smoothing reactor
Irms (A)	57.6
Peak factor	1.46
THD (I) as a %	3.4
Harmonic Irms (A)	2

Fig. 26: “shunt-type” active harmonic conditioner associated with a variable speed drive with smoothing reactor - current characteristics.

3 Hybrid active harmonic conditioners

Harmonic compensation needs are many and varied, since the requirement may be to guarantee:

- non-disturbance of a “clean” power network by a disturbing load,
- or proper operation of a sensitive load (or power network) in a disturbed environment,
- or both these objectives simultaneously!

The problem of harmonic compensation can thus be handled at two levels (exclusive or combined):

- parallel compensation by current source downstream of the point in question: this is the

“shunt-type” solution described in the previous chapter,

- serial compensation by implementing an upstream voltage source.

The structures that we shall refer to as “hybrid” hereafter in this document are those which simultaneously implement both solutions, as shown for example in **figure 27**.

They use passive filters and active harmonic conditioners. We have chosen to describe three of the many alternatives available.

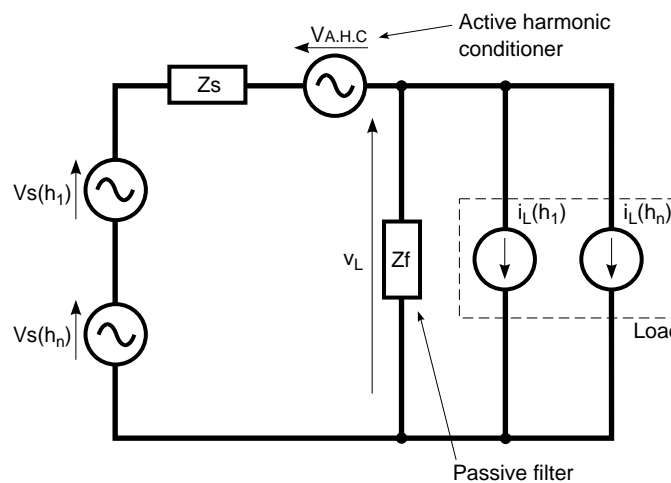

Fig. 27: active/passive hybrid conditioners - example.

3.1 The “parallel/series” hybrid structure

The diagram in **figure 28** illustrates the main subassemblies of this structure, namely:

- one (or more) bank(s) of resonant passive filters (Fi), parallel-connected with the disturbing load(s),
- an active harmonic conditioner, made up of:
 - a magnetic coupler (Tr), the primary of which is inserted in series with the passive filter(s),
 - an inverter (MUT) connected to the secondary of the magnetic coupler. The active harmonic conditioner is controlled so that:

$$V_{fa} = K I_{SH}$$

where:

Vfa: voltage at the magnetic coupler terminals,

K: value in “ohm” fixed for each order,

ISH: harmonic current from the source.

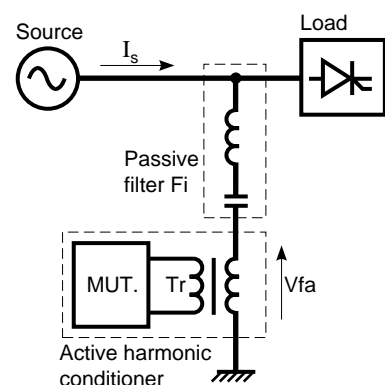

Fig. 28: “parallel/series type” hybrid conditioners - one-line diagram.

In this configuration the active harmonic conditioner only acts on the harmonic currents and increases the effectiveness of the passive filters:

- it prevents amplification of upstream harmonic voltages at the anti-resonance frequencies of the passive filters,
- it considerably attenuates harmonic currents between load and source by “lowering” global impedance (passive filters plus active harmonic conditioner).

Since not all the power network current flows through the active harmonic conditioner, the components of the latter can be downsized (and in particular the magnetic coupler).

This structure is thus ideal for treating high voltage and power networks, while at the same time ensuring rephasing of fundamental components.

Its main drawback is that the passive filters depend on the type of load, thus requiring a preliminary study.

Finally, virtually all the pre-existing harmonic voltages (on the source) are present on the load side. This configuration can therefore be compared with the “shunt type” active harmonic conditioner.

3.2 The “series/parallel” hybrid structure

The diagram in **figure 29** shows that this structure contains the main subassemblies of the previous structure, the only difference being in the connection point of the coupler primary (in series between source and load).

The active harmonic conditioner control law is the same: its aim is for the active harmonic conditioner to develop a voltage which opposes circulation of harmonic currents to the source. It therefore acts as an impedance (of value K fixed for each order) for harmonic frequencies. Passive filtering is thus more efficient (as the presence of this serial “impedance” forces circulation of the harmonic load currents to the passive filters). Moreover, the serial filter isolates the load of the harmonic components already existing on the source and prevents passive filter

overload. This topology is thus most often referred to as an “harmonic isolator” since, in some respects, it isolates the source of a disturbing load, and, reversely, prevents overload of a passive filter by upstream disturbance. It should be noted that this topology generates sizing and protection problems for the magnetic coupler, since:

- total load current flows through this coupler,
- a very high current wave is applied in the event of a short-circuit.

A possible solution to both problems may be to use a transformer with an additional secondary winding (see **fig. 30**).

Compensation then takes place “magnetically” by directly acting on the flow.

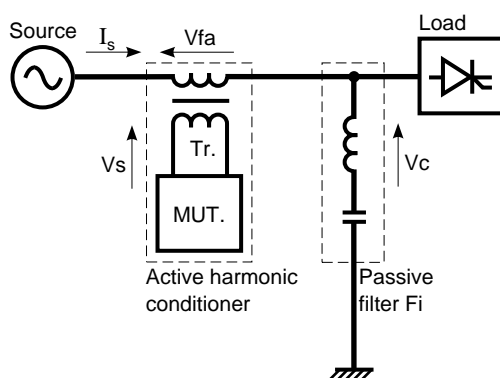

Fig. 29: “series/parallel type” hybrid conditioners.

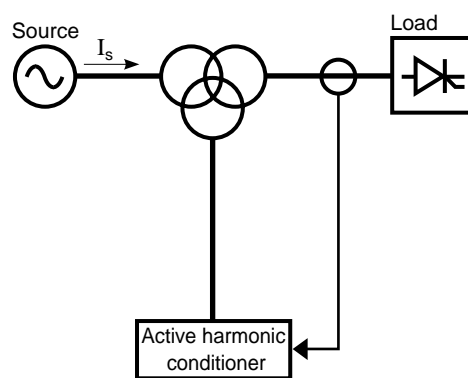

Fig. 30: hybrid conditioner with injection by transformer.

3.3 “Parallel” combination of passive filters and active harmonic conditioner

The principle consists of “parallel” connection of one (or more) tuned passive filter(s) and a “shunt type” active harmonic conditioner (see **fig. 31**).
 In this case also, the active harmonic conditioner and the passive filter prove the ideal combination. It may prove useful to limit (by the FFT technique), the action of the active harmonic conditioner to the orders not treated by the passive filters.

This structure is used (as applicable) to:

- improve the harmonic cancellation obtained using only passive filters,
- limit the number of orders of passive filters,
- improve the effectiveness of the active harmonic conditioner only (for the same power effectiveness of the active harmonic conditioner).

Nevertheless, this combination does not prevent passive filter overloads or the effects of anti-resonance with power network impedance.

In short

These hybrid structures do not possess the “universal” character of the “shunt type” active harmonic conditioner as passive filters need to be chosen (in terms of type, number of orders and tuning frequencies) according to the kind of harmonic currents generated by the load. The presence of the active harmonic conditioner downsizes the passive filters and reinforces their

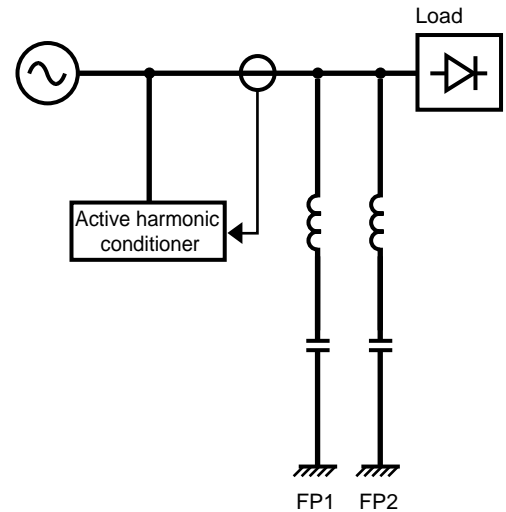

Fig. 31: “parallel” connection of active harmonic conditioner and passive filters - principle.

effect. Vice versa, the addition of an active harmonic conditioner of reduced power to an existing installation increases the efficiency of existing passive filters.

3.4 The performances of hybrid structures

Prototypes have been designed, produced and tested in partnership with Electricité de France (which is the main power utility in France). These models comprised two banks of resonant passive filters tuned on orders 5 and 11 (harmonic compensation of a UPS-type load) or 5 and 7 (variable speed drive load).

The result of the tests combining two types of hybrid filters with a frequency converter (variable speed drive for asynchronous motor) is given below.

“Parallel/series” configuration (see fig. 28)

The test circuit characteristics are defined in the table in **figure 32** .

Comments: this topology is not suitable for treating power networks with a high upstream voltage THD. However, its “current”

Circuit characteristics	
Source	400 V, three-phase, 600 kVA, 5%, THD (Vs) < 1.5%
Load	130 kW, 70% load, 0.15 mH smoothing reactor.
Measurements taken	
THD (I _L)	35%
THD (I _s)	9%
THD (V _L)	2%

Fig. 32: “parallel/series” type conditioner - characteristics and results.

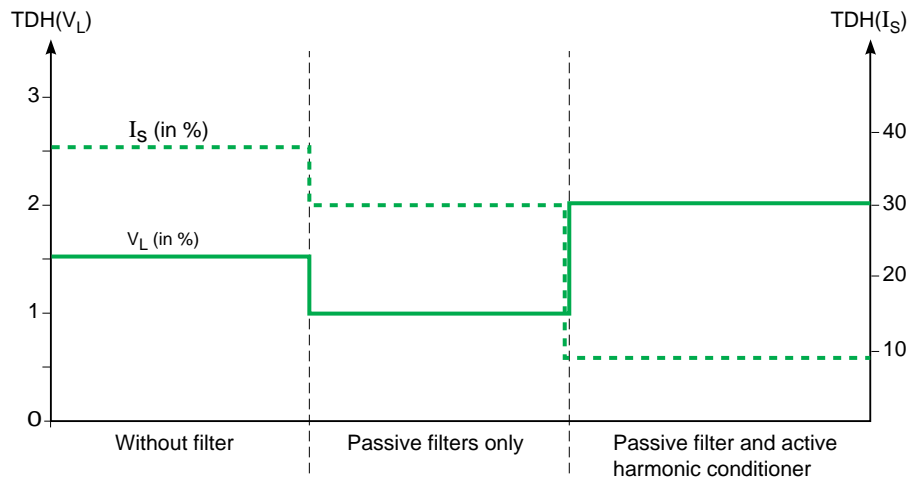

Fig. 33: "parallel/series type" hybrid conditioner associated with a variable speed drive - evolution of THD (V_L) and THD (I_S).

performances are totally respectable (the THD (I) is reduced from over 35% to 9%) (see **fig. 33**). It is thus particularly well suited for treating power networks with low upstream THD, or for which serial insertion of a device is particularly problematic.

"Series/parallel type" configuration (see fig. 29)

The test circuit characteristics are defined in the table in **figure 34**.

Comments: the performances are in this case also totally satisfactory even if the quality of the source voltage (THD (u) very low) does not allow to appraise performance in terms of isolation. The source current THD is however reduced from more than 35% to 11% (see **fig. 35**).

Circuit characteristics

Source	400 V, three-phase 600 kVA, 5 %, THD (V_S) < 1.5 %
Load	130 kW, 70% load, 0.15 mH smoothing reactor.

Measurements taken

THD (I_L)	35 %
THD (I_S)	11 %
THD (V_L)	2.1 %

Fig. 34: "series/parallel type" hybrid conditioner: characteristics and result.

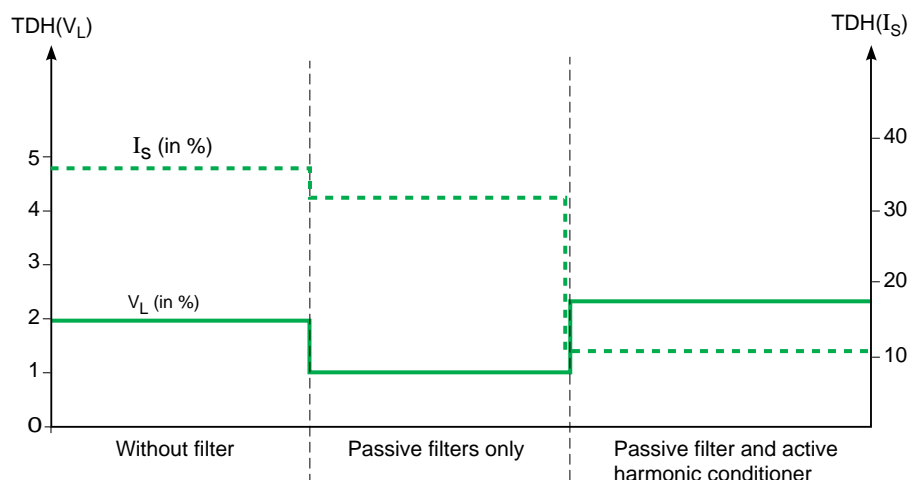

Fig. 35: "series/parallel type" hybrid conditioner associated with a variable speed drive - reading of TH (V_L) and THD (I_S).

Passive filter current remains constant and is thus representative of isolation from the source.

Additional tests proved that for very high upstream distortion (THD (V) = 11%), voltage quality at the load terminals continued to be good (THD (V_L) = 4.7%).

Characteristics of the active solutions

We have now dealt with series and parallel type active harmonic conditioners and with hybrid structures.

To round off this chapter, we propose to summarise the qualities of these various “active solutions” used to combat harmonic disturbance.

The table in **figure 36** shows that, except for a few special cases, the “shunt type” active harmonic conditioner and the parallel-connected structure are the solutions to be preferred in low voltage.

Type of filter Criterion	⇒ “Series”	“Shunt” hybrid	“Parallel” hybrid	“Parallel/series” hybrid	“Series/parallel type”
Schematic diagram					
	A.H.C.: Active Harmonic Conditioner	P.F.: Passive Filter			
Action on	Uh/source	Ih/load	Ih/load	Ih/load	Ih/load, Uh/source
Performance	+++	+++	+++	++	++
Active harmonic conditioner sizing	fund + harm	harm.	harm.	harm.	fund + harm
Short-circuit impact	great	none	none	none	great
Insertion	difficult	easy	easy	easy	difficult
Improvement of DPF	no	possible	yes	yes	yes
Open-endedness	no	yes	yes	no	no
Resonance risk	NA (not applicable)	NA (not applicable)	yes	no	no

Fig. 36: summary of the various “active solutions” to combat harmonic disturbance.

4 Implementing a “shunt type” active harmonic conditioner

We would first like to emphasise that our aim is not to act as a “selection guide” between the various types of harmonic compensation techniques (both active and passive), but rather to present the criteria used to size and insert the active harmonic conditioners. Furthermore, a selection guide would imply that the various solutions given are available in product form. At present, given that both the “traditional”

solutions and the hybrid solutions require in-depth study and suitable solutions, only the shunt type active harmonic conditioners are available on the market (they require merely a simple study).

We shall thus concentrate on identifying the main parameters that “potential” active harmonic conditioner users need to know in order to make the right choice.

4.1 Objective and context

Knowing the “mechanisms”

The main problem of harmonic phenomena is undeniably linked to their very weak visibility. Although it is usually easy to observe deterioration in wave quality (voltage and/or current) at one or more points, the combinational function between the various sources (self-sufficient or not), loads and topology of the power network is no simple matter! Moreover, the association between harmonic phenomena (often overlooked) and the malfunctions observed in the power network components (often random) is not instinctive.

Knowing the power network and its topology

The first preliminary requirement thus concerns the power network environment: implementation of an harmonic compensation technique requires knowledge of the entire power network (sources, loads, lines, capacitors) and not just a fragmented view limited merely to the zone concerned. This single-line diagram is in some respects the first component of our “tool box”.

Carrying out an “inventory”

We have first placed an harmonic distortion analyser in this “tool box”, vital for quantifying disturbance at various points of an existing installation.

Identifying and characterising disturbing equipment

We need to identify the main disturbing equipment(s) and their respective spectra. The latter can be obtained either by measurements or by consulting the technical specifications provided by each manufacturer.

Defining the harmonic compensation objective

The second preliminary requirement concerns the actual objective of the action considered: the method used differs considerably according to

whether you wish to correct malfunctioning observed, or to ensure compliance with the specifications of power utility or a non-linear load manufacturer. Short term power network changes must also be taken into consideration. For example this stage must enable identification of at least:

- the type of compensation (global or local),
- the power rating at the node considered,
- the type of correction required (on voltage and/or current distortions),
- the reactive energy compensation need.

Once the above analyses are complete, the most advantageous technical and economic solution must be chosen. The same objective often has several technical possibilities, and the problem is in most cases to make a choice according to the individual difficulties of each electrical installation. For example, isolation or decoupling by impedance of disturbing loads is easily carried out on new installations provided it is considered in the design phase. However it frequently generates unacceptable difficulties on existing power networks.

It is thus obvious that no “active” solutions (regardless of the type) can be systematically chosen, but that an analytical approach is required in which active harmonic conditioner cost alone is not necessarily the most important factor.

Although Active harmonic conditioners have undeniable advantages over passive filters, they are not necessarily preferred particularly for existing installations already equipped with passive filters. The insertion of a serial or parallel type active harmonic conditioner, after study, is a good solution.

We shall now use experience acquired on site to describe the implementation of a “shunt-type” active harmonic conditioner which is the simplest solution.

4.2 The insertion point of a “shunt-type” active harmonic conditioner

The connection principle of a “shunt type” active harmonic conditioner is shown in **figure 37**. In our example it is inserted in parallel mode in the

LV switchboard of an installation, and the only interaction with the power network to be treated, is the insertion of the current sensors.

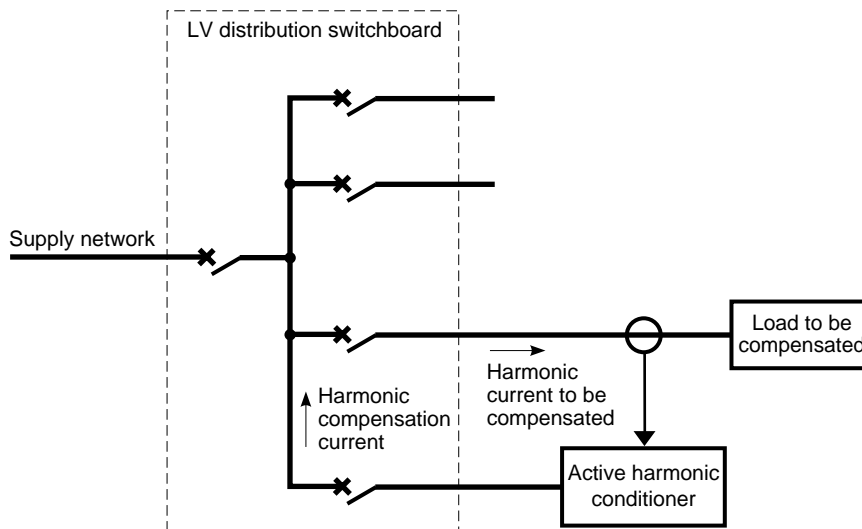

Fig. 37: connection of a “shunt type” active harmonic conditioner: principle.

As regards insertion of the active harmonic conditioner, harmonic compensation can be considered at each level of the tree structure shown in **figure 38**.

The compensation mode may be termed global (position “A”), semi-global (position “B”) or local (position “C”) according to the point of action chosen. Although it is hard to lay down strict rules, it is obvious that if disturbance is caused by a large number of small loads, the “mode” preferred will be global, whereas if it is caused by a single high power disturbing load, the best result will be achieved using the local “mode”.

Local harmonic compensation

The “shunt type” active harmonic conditioner is directly connected to the load terminals. This mode is the most efficient provided that the number of loads is limited and that the power of each load is significant compared with global power. In other terms, the loads treated must be the main generators of the harmonic disturbances.

Circulation of harmonic current in the power network is avoided, thus reducing losses by Joule effect in upstream cables and components (no oversizing of cables and transformers) as well as reducing disturbances of sensitive loads. It is worth pointing out, however, that the “shunt type” active harmonic conditioner lowers source impedance at the connection point, and thus slightly increases current total harmonic distortion between the connection point and the load.

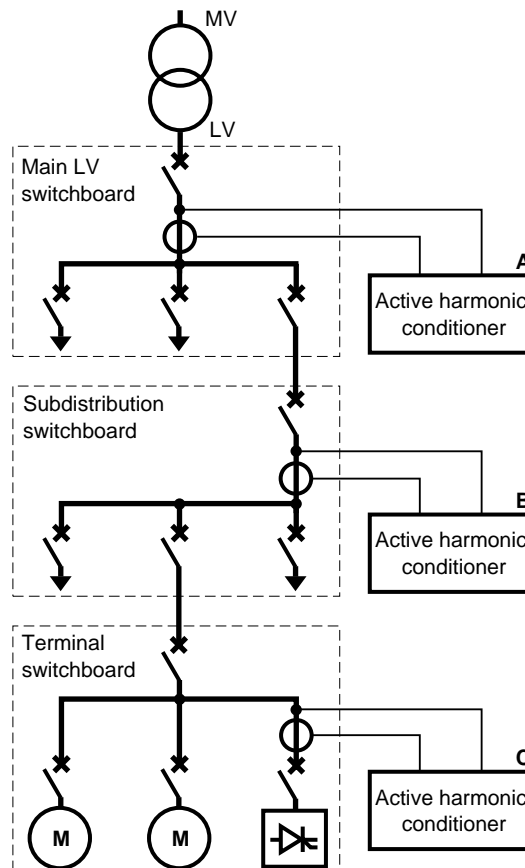

Fig. 38: the various insertion points of a “shunt-type” active harmonic conditioner: principle.

Semi-global compensation

The active harmonic conditioner, connected to the input of the LV subdistribution switchboard, treats several sets of loads.

The harmonic currents then flow between the MLVS and the loads of each feeder.

This type of compensation is ideal for multiple disturbing loads with low unitary power, e.g. on floors in service sector buildings (office equipment and lighting systems).

It also makes it possible to benefit from non-algebraic summing between loads, at the cost of a slight increase in losses by Joule effect on each feeder treated.

NB: this type of compensation can also be applied to a single feeder, thus limiting harmonic compensation to a single type of load (see fig. 37).

Global compensation

This form of compensation contributes rather to compliance with the point of common coupling according to "power utility" requirements, than to the reduction of internal disturbances in the customer's power network. Only the power transformer(s) actually derive direct advantage from harmonic compensation. Nevertheless, this form has a serious advantage for operation in autonomous production mode as a result of the numerous interactions between disturbing loads and generator sets with high harmonic impedance.

However, compared with local compensation, this compensation technique results in a reduction in active harmonic conditioner power rating which benefits from the non-algebraic summing of the disturbing loads throughout the power network.

4.3 Sizing a "shunt-type" active harmonic conditioner

The main factor to consider when sizing a "shunt type" active harmonic conditioner is its power rating (**or more precisely its rms current**):

the rms current $I_{CA\ RMS}$ is the current that can be permanently generated by the active harmonic conditioner.

Other characteristic active harmonic conditioner factors are its **bandwidth** and its **dynamic capacity**:

■ the active harmonic conditioner bandwidth is defined by n_{min} and n_{max} , the (minimum and maximum) action orders of the active harmonic conditioner.

The following can be written:

$$I_{CA\ RMS}(A) = \sqrt{\sum_{n=n_{min}}^{n=n_{max}} I_{CA(n)}^2}$$

■ the active harmonic conditioner current tracking dynamic capacity (expressed by $\frac{di}{dt}$) is the capacity of the active harmonic conditioner to "track" rapidly varying references.

NB: these last two factors are not considered to affect size, since they form a characteristic inherent in the active harmonic conditioner and not an adjustable parameter.

Choosing nominal rating:

Provided that the spectrum of the current to be treated I_{CH} is known, the nominal current of the active harmonic conditioner $I_{N\ CA\ RMS}$, can be determined such that:

$$I_{N\ CA\ RMS}(A) \geq \sqrt{\sum_{n=n_{min}}^{n=n_{max}} I_{CH(n)}^2}$$

Provided that the above condition is met, the "new" current total harmonic distortion (upstream) can be calculated once the active harmonic conditioner is put into operation:

$$THD\ I(\%) = \frac{\sqrt{\sum_{n=2}^{n=n_{min}} I_{CH(n)}^2 + \sum_{n=n_{max}+1}^{n \rightarrow \infty} I_{CH(n)}^2}}{I_{CH(1)}}$$

This formula is used to determine whether the maximum theoretical performance of the active harmonic conditioner is compatible with the target objective. It can be simplified still further, if we consider the specific case of MGE UPS Systems products for which $n_{min} = 2$ and $n_{max} = 23$:

$$THD\ I(\%) = \frac{\sqrt{\sum_{n=24}^{n \rightarrow \infty} I_{CH(n)}^2}}{I_{CH(1)}}$$

Furthermore, the above nominal rating selection rule must be weighted by the following practical considerations:

- the harmonic spectrum of most loads is significant only in the band h3 to h13,
- the purpose of inserting the active harmonic conditioner is not to cancel the THD (I) but to limit it below a predefined level (e.g. 8%),
- an active harmonic conditioner can be chosen with a rating lower than $I_{N\ CA\ RMS}$, and then operate in permanent saturation (by permanent, automatic limitation of its rms current).

Finally, parallel-connection of a number of active harmonic conditioners at the same insertion point is technically feasible, a solution which may prove of interest for upgrading of a pre-equipped network.

4.4 Application examples

Reduction of line distortions

As regards high rise buildings or buildings occupying a large ground surface area, the main problem concerns the lengths of the lines between the point of common coupling (MV/LV transformer) and the loads.

This is because, irrespective of voltage wave quality at the origin of the installation and of the precautions taken for the lines (choice of cable diameter, splitting,...), voltage total harmonic distortion increases at the same time as "altitude" or distance!

As from a specific point, therefore, voltage distortion can be considered unacceptable in permanent mode, and the "shunt-type" active harmonic conditioner provides an interesting alternative to traditional solutions (e.g. isolation by suitable LV/LV coupling transformers).

Let us consider the example of a three-phase UPS supplying a set of "computer" loads at the end of a 60 m line. We then observe a voltage distortion of 10.44% (phase to phase) and of 15.84% (phase to neutral) at load level. This deterioration is the result of a combination of two factors, namely:

- UPS sensitivity (with non-PWM control) to the non-linear characteristic of the downstream current,
- the mainly inductive characteristic of the line which amplifies distortions.

The proposed solution is illustrated in **figure 39** and is based on insertion of a "shunt-type" active harmonic conditioner as close as possible to loads. Performances are then totally satisfactory with respect to the objective: the THD (U) drops to 4.9% phase to phase and to 7.2% phase to neutral.

Combination of "shunt-type" active harmonic conditioner and passive components

Effect on tariffs

A pumping station is designed to maintain constant water pressure on the drinking water distribution network (see **fig. 40**). The motor-driven pump P1 is thus controlled by a variable speed drive with frequency converter.

In this particular instance, the main objective was compliance of the source current spectrum with the power utility's requirements. With no filtering device, the authorised harmonic emission level was:

- greatly exceeded on order 5,
- more or less reached on orders 7 and 11.

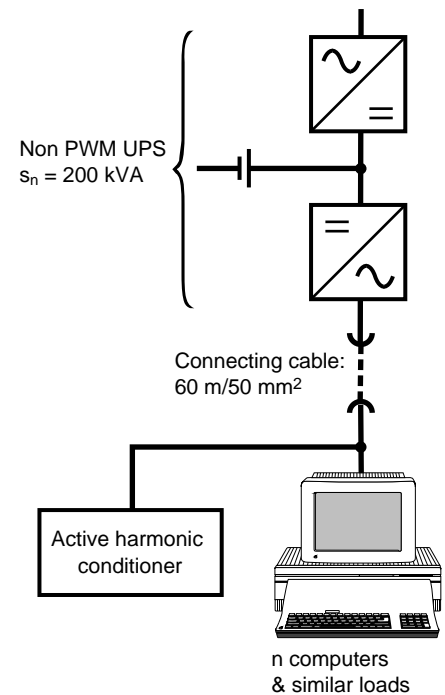

Fig. 39: using an active harmonic conditioner to treat voltage total harmonic distortion at the end of a 60 m cable.

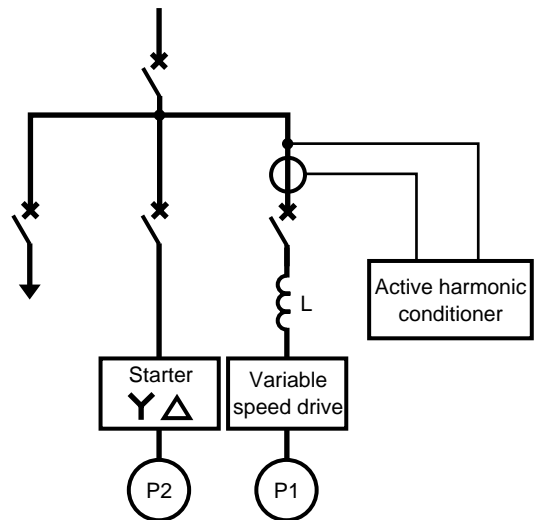

Fig. 40: pumping station diagram (main low voltage switchboard).

The choice made is a combination of smoothing reactors and a "shunt type" active harmonic conditioner: performances are shown in **figure 41**.

- All the harmonic orders are well below authorised emission limits.
- The current total harmonic distortion is reduced by 89%.

An advantage particularly appreciated by the customer is the reduction of his contracted power (in kVA).

This example also shows that the combination of an active harmonic conditioner + smoothing reactor is particularly suitable in view of the high degree of disturbance.

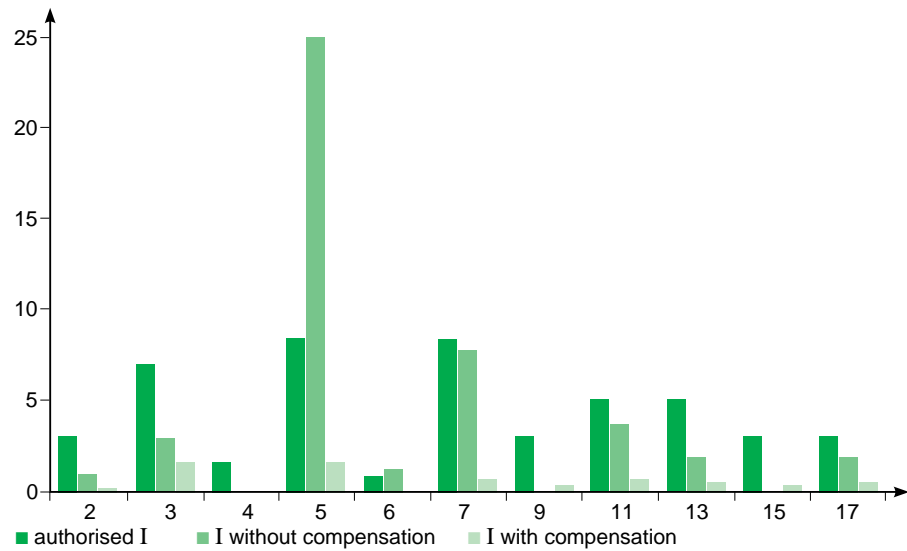

Fig. 41: pumping station - spectral representation of harmonic currents.

5 Conclusion

The profusion of non-linear loads makes harmonic distortion of power networks a phenomenon of increasing amplitude, the effects of which cannot be ignored since almost all the power network components are in practice affected.

Up to now the most popular solution was passive filtering. However, an attractive alternative to this complex and non risk-free solution is now commercially available in the form of active harmonic conditioners.

These devices use a structure of the static power converter type. Consequently, semiconductor

progress means that converters, which are normally harmonic disturbers, now form efficient, self-adaptive harmonic compensation devices .

The easy to use, self-adaptive “shunt- type” active harmonic conditioner, which requires virtually no preliminary studies prior to use, is the ideal solution for harmonic compensation on a non-linear load or LV distribution switchboard.

However it does not necessarily replace passive filters with which it can be combined advantageously in some cases.

Appendix: review of harmonic phenomena

Definition and characteristic quantities

Joseph FOURIER proved that all non-sinusoidal periodic functions can be represented by a sum of sinusoidal terms, the first one of which, at the recurrence frequency of the function, is said to be fundamental, and the others, at multiple frequencies of the fundamental, are said to be harmonic. A DC component may complete these purely sinusoidal terms.

FOURIER's formula:

$$y(t) = Y_0 + \sum_{n=1}^{\infty} Y_n \sqrt{2} \sin(n \omega t - \varphi_n)$$

where:

- Y_0 : DC component value, generally nil and considered hereafter to be nil,
- Y_n : rms value of the nth harmonic component,
- ω : angular frequency of the fundamental,
- φ_n : displacement of the nth harmonic component.

The notion of harmonics applies to all periodic phenomena irrespective of their nature, and particularly to AC current.

rms value of a non-sinusoidal alternating quantity

There is similarity between the normal expression of this rms value calculated from the time evolution of the alternating quantity $y(t)$ and the expression calculated using its harmonic content:

$$Y_{rms} = \sqrt{\frac{1}{T} \int_0^T y^2(t) dt} = \sqrt{\sum_{n=1}^{\infty} Y_n^2}$$

Note that when harmonics are present, the measuring instruments must have a wide bandwidth (> 1 kHz).

Total harmonic distortion

Total harmonic distortion is a parameter globally defining distortion of the alternating quantity:

$$THD (\%) = 100 \frac{\sqrt{\sum_{n=2}^{\infty} Y_n^2}}{Y_1}$$

There is another definition which replaces the fundamental Y_1 with the total rms value Y_{rms} . This definition is used by some measuring instruments.

Individual harmonic ratio

This quantity represents the ratio of the value of an harmonic over the value of the fundamental (Y_1), according to the standard definition or over the value of the alternating quantity (Y_{rms}).

$$H_n (\%) = \frac{Y_n}{Y_1}$$

(Frequency) spectrum

Representation of harmonic amplitude as a function of their order: harmonics value is normally expressed as a percentage of the fundamental.

Power factor (PF) and Displacement Power Factor (DPF)

It is important not to confuse these two terms when harmonics are present, as they are equivalent only when currents and voltages are completely sinusoidal.

- The power factor (λ) is the ratio between active power P and apparent power S :

$$\lambda = \frac{P}{S}$$

- The displacement power factor ($\cos \varphi_1$) relates to fundamental quantities, thus:

$$\cos \varphi_1 = \frac{P_1}{S_1}$$

In pure sinusoidal waveform:

$$\cos \varphi_1 = \cos \varphi = \lambda$$

Distortion factor

The IEC 146-1-1 defines this factor as the ratio between the power factor and the displacement power factor $\cos \varphi_1$:

$$\cos \varphi_1 : \nu = \frac{\lambda}{\cos \varphi_1}$$

It is always less than or equal to 1.

Peak factor

The ratio of peak value over rms value of a periodic quantity.

$$F_C = \frac{Y_{peak}}{Y_{rms}}$$

Origin and transmission

Linear and non-linear loads

A load is said to be linear when there is a linear relationship (linear differential equation with constant factors) between current and voltage. In simpler terms, a linear load absorbs a sinusoidal current when it is supplied by a sinusoidal voltage: this current may be displaced by an angle ϕ compared with voltage.

When this linear relationship is not verified, the load is termed non-linear. It absorbs a non-sinusoidal current and thus harmonic currents, even when it is supplied by a purely sinusoidal voltage (see [fig. 42](#)).

Voltage and current total harmonic distortion

A non-linear load generates harmonic voltage drops in the circuits supplying it. In actual fact all upstream impedances need to be taken into consideration right through to the sinusoidal voltage source.

Consequently a load absorbing harmonic currents always has a non-sinusoidal voltage at its terminals. This is characterized by the voltage total harmonic distortion:

$$\text{THD (\%)} = 100 \frac{\sqrt{\sum_{n=2}^{n=\infty} (Z_n I_n)^2}}{U_1}$$

where Z_n is the total source impedance at the frequency of harmonic n , and I_n the rms value of harmonic n .

The greater the non-linearity of the load, the larger the voltage distortion and the higher the order of the harmonic currents (inductive source impedance $2\pi f_1 n L$).

Remember that current total harmonic distortion is:

$$100 \frac{\sqrt{\sum_{n=2}^{n=\infty} I_n^2}}{I_1}$$

In order to illustrate the main types of behaviour of the main sources, [figure 43](#) shows the evolution of their impedances as a function of frequency.

For further details, readers can consult "Cahier Technique" no. 159.

Do not forget that large diameter cables are mainly inductive and that small diameter cables have a non-negligible resistance.

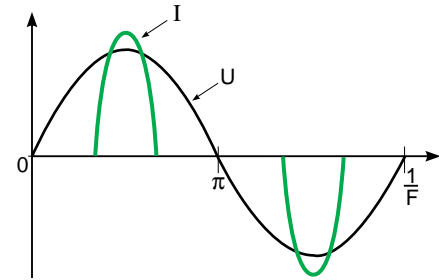

Fig. 42: current absorbed by a non-linear load.

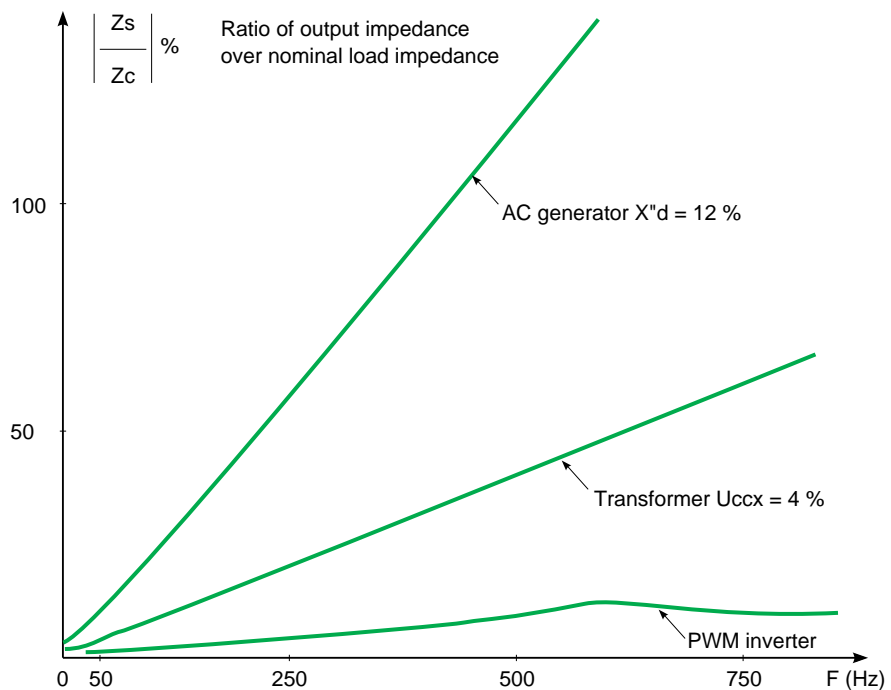

Fig. 43: output impedance of the various sources as a function of frequency.

Deforming loads

Most deforming loads are static converters. They may be powerful and few in number, or low-power and plentiful. Some examples are:

- fluorescent lamps, dimmers,
- computers,
- electrical household appliances (television sets, microwaves, induction plates).

Nowadays the proliferation of low power devices is chiefly responsible for increased voltage harmonic distortion in power networks.

Figure 44 illustrates the current absorbed by a few loads, and **figure 45** the matching harmonic spectra (typical values).

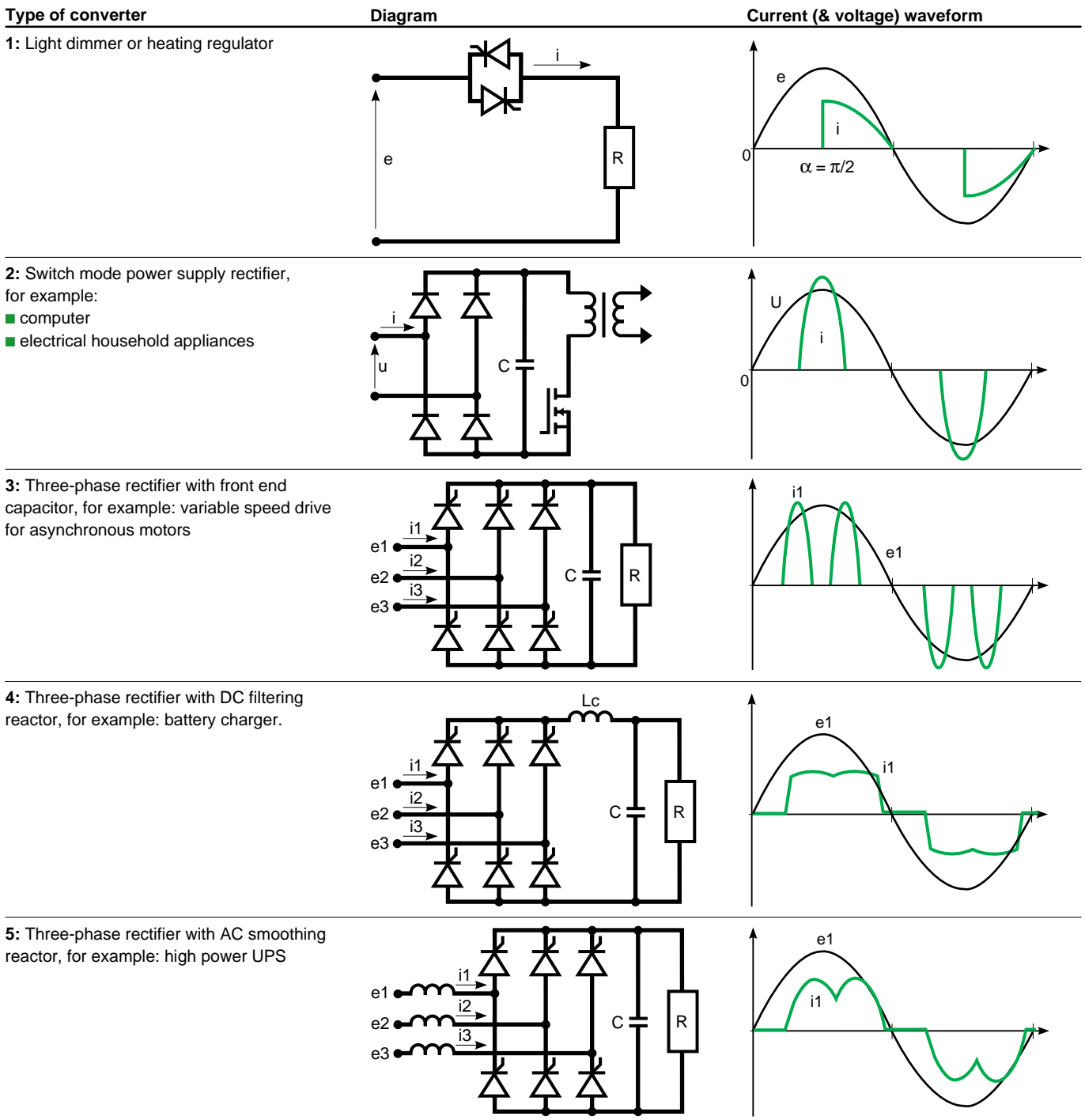

Fig. 44: curve of the current absorbed by some non-linear loads.

N°	H ₃	H ₅	H ₇	H ₉	H ₁₁	H ₁₃	H ₁₅	H ₁₇	H ₁₉
1	54	18	18	11	11	8	8	6	6
2	75	45	15	7	6	3	3	3	2
3	0	80	75	0	40	35	0	10	5
4	0	25	7	0	9	4	0	5	3
5	0	33	3	0	7	2	0	3	2

Fig. 45: example of the harmonic spectrum of currents absorbed by the loads in figure 44.

Harmful effects of harmonics

Effects on low current appliances and systems

Harmonic distortion may cause:

- malfunctioning of certain appliances which use voltage as a reference to generate semi-conductor controls or as a time base to synchronise certain systems;
 - Disturbances by creating electromagnetic fields. Thus when “data transmission lines” circulate in the vicinity of power lines through which harmonic currents flow, they may be subjected to induced currents able to cause malfunctioning of the equipment to which they are connected;
 - finally circulation of harmonic currents in the neutral provokes a voltage drop in this conductor: thus in the case of the TN-C earthing system, the frames of the various devices are no longer at the same potential, which may well interfere with information exchange between “intelligent” loads.
- Moreover current circulates in the metallic structures of the building and creates disturbing electromagnetic fields.

Effects on capacitors

Capacitor impedance decreases as frequency increases. Consequently if voltage is distorted, relatively strong harmonic currents flow in these capacitors whose aim is to improve the DPF. Furthermore the presence of reactors in the different parts of the installation reveals a risk of resonance with the capacitors which may considerably increase the amplitude of an harmonic in the capacitors. In practice, capacitors should never be connected on installations with a voltage total harmonic distortion greater than 8%.

Effects on transformers

Harmonics generate additional losses in the transformers:

- losses due to Joule effect in the windings, accentuated by the skin effect,
- losses by hysteresis and eddy current in the magnetic circuits. To take these losses into

consideration, a standardised empirical formula (NFC 52-114) is used to calculate the derating factor k to be applied to a transformer.

$$k = \frac{1}{\sqrt{1 + 0.1 \sum_{n=2}^{\infty} H_n^2 n^{1.6}}} \text{ where } H_n = \frac{I_n}{I_1}$$

For example where

H₅ = 25% ; H₇ = 14% ; H₁₁ = 9% ; H₁₃ = 8%, the factor k is 0.91.

Effect on ac generators

In the same way as for the transformer, the harmonics create additional losses in the windings and magnetic circuit. Furthermore the harmonics create pulsating torques which generate vibrations and additional overheating in the damping windings. Finally as the subtransient reactance is relatively large, the voltage total harmonic distortion quickly rises with the increase in harmonic currents. In practice, limitation of the current total harmonic distortion to a value less than 20% is accepted, with a limit of 5% for each harmonic order. Beyond these values, manufacturers must be consulted as to the spectrum of current really absorbed by the loads.

Effect on power lines and in particular on the neutral conductor

Harmonic currents create additional losses in conductors accentuated by the skin effect. Losses are even more serious when single-phase loads absorb harmonic currents 3 and multiples of 3. These currents are in phase and are added together in the neutral conductor.

With, for example, an harmonic 3 of 75%, the current flowing in the neutral is 2.25 times the fundamental. The current in each phase is only

$$\sqrt{1 + 0.75^2} = 1.25 \text{ times the fundamental.}$$

Special attention must thus be paid to the sizing of the neutral conductor when non linear loads are present. The TN-C earthing system is strongly advised against.

Standards and recommendations

Electricity is today regarded as a product, especially in Europe with the directive of July 25th 1985.

The EN 50160 standard defines the main characteristics at the customer's point of common coupling for a low voltage public supply network, and in particular the harmonic voltage levels (class 2 levels in the table in [figure 47](#)). These are the levels of compatibility in terms of electromagnetic compatibility (see [fig. 46](#)). In addition to this European standard, the maximum levels of the various harmonic orders are defined in IEC 61000.

■ **For low voltage public supply networks:** IEC 61000-2-2 and CIGRE recommendations.

■ **For medium and high voltage public supply networks:** IEC draft standard for medium voltage and CIGRE recommendations.

■ **For low voltage and medium voltage industrial installations:** IEC 61000-2-4. By way of illustration, the table taken from this standard gives the harmonic levels of compatibility in three standard situations (classes) (see [fig. 47](#)).

To ensure these levels are not reached, **limits must be set for the disturbances emitted (emission level)** by devices either considered separately, or for a group of devices as regards their point of connection to the power network. **IEC 61000-3-2 deals with low voltage and devices absorbing current of less than 16 A, and the IEC 61000-3-4 draft guide deals with devices absorbing current greater than 16 A.** Although there is no standard for industrial applications, there is a sort of "consensus" concerning the notion of stages for authorisation of connection to the public supply network: stage 1 means automatic acceptance for low powers with respect to contracted power, stage 2 means acceptance with reservations (a single consumer must not exceed a level representing half the level of compatibility) and stage 3 means exceptional and provisional acceptance when the previous level is exceeded. Finally, to guarantee proper operation of devices, **these devices must be able to withstand levels of disturbance greater than the levels of compatibility** given in [figure 47](#) should these levels be overshoot (permissible temporarily): this is their level of immunity.

Level of disturbance

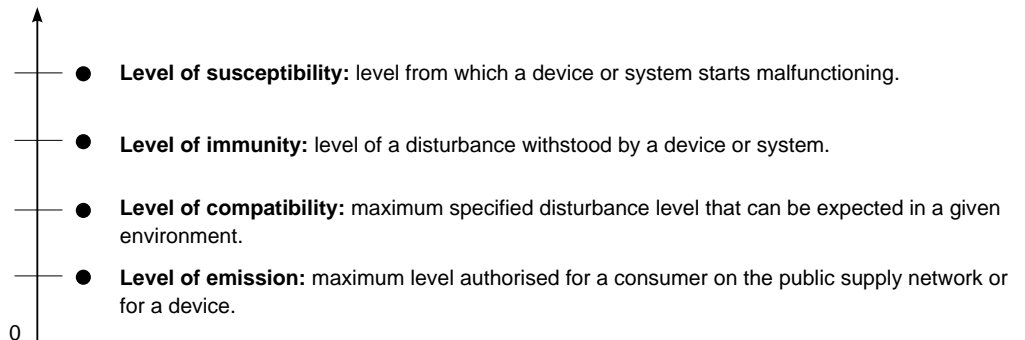

Fig. 46: the various levels of disturbance for compatibility of non linear/sensitive equipment.

Harmonic order	Class 1 (sensitive devices and systems)	Class 2 (public and industrial supply networks)	Class 3 (for connection of large non-linear loads)
2	2	2	3
3	3	5	6
4	1	1	1.5
5	3	6	8
6	0.5	0.5	1
7	3	5	7
8	0.5	0.5	1
9	1.5	1.5	2.5
10	0.5	0.5	1
11	3	3.5	5
12	0.2	0.2	1
13	3	3	4.5
THD	5%	8%	10%

Fig. 47: ratio (as a %) of acceptable harmonic voltages (compatibility).

Schneider Electric

Direction Scientifique et Technique,
Service Communication Technique
F-38050 Grenoble cedex 9
Fax : (33) 04 76 57 98 60

DTP: Sodipe - Valence
Edition: Schneider Electric
Printing: Imprimerie du Pont de Claix - Claix - France - 1000
- 100 FF -