



Global Advanced Research Journal of Engineering, Technology and Innovation (ISSN: 2315-5124) Vol. 2(1) pp. 001-010, January, 2013
Available online <http://garj.org/garjeti/index.htm>
Copyright © 2013 Global Advanced Research Journals

Full Length Research Paper

On-line Parameter Identification Scheme for Vector Controlled Drive of Synchronous Reluctance Motor without Shaft Encoder

Mona Moussa F* and Yasser Dessouky G

Arab Academy for Science and Technology and Maritime Transport Miami, P.O. Box: 1029, Alexandria, Egypt.

Accepted 09 January 2012

The control characteristics of a SynRM are investigated on the basis of a simple parameter estimation system. To control synchronous reluctance motors (SynRMs), position and speed sensors are indispensable because the current should be controlled depending on the rotor position. Consequently, a sensorless control method based on extended electromotive force (EEMF) models considering magnetic saturation is proposed for SynRM. A decoupled vector control for SynRM drive has been presented. One of the most important advantages of the vector control is its ability to change the magnitude, frequency, and phase angle of the phase supply voltages, due to the independent control of flux and torque. Moreover, an effective and simple online parameter identification method for sensorless control is presented to estimate the armature resistance and the q-axis inductance of SynRMs. The identification method is developed based on the fact that, in practice the d-axis inductance is almost constant. The position sensorless control using identified motor parameters is realized, and simulation results are included to prove the effectiveness of the overall control system under different operating conditions. Therefore, the proposed on-line identification scheme gives fast and accurate transient performance over a wide range of speed and torque operation.

Keywords: Extended electromotive force (EEMF), magnetic saturation, online parameter identification, sensorless control, synchronous reluctance motors (SynRMs).

INTRODUCTION

Synchronous reluctance motors (SynRMs) have gained much attention in recent years in various industrial and automation applications. Some benefits of SYRM are low cost, absence of rotor losses, simple structure, absence of permanent magnet, and enduring ability for applications. The cold rotor without magnets or windings is mechanically robust for high speed operation (Jovanovic et al., 2002; Lipo, 1991; Vagati et al., 2000).

The rotor saliency characteristic with the difference between the d-axis and q-axis inductance is useful for the sensorless and field weakening controls (Vagati et al., 1997; Matsuo and Lipo, 1995; Seog-Joo et al., 1999; Chalmers and Musaba, 1998). As a result, the SynRM is easier to manufacture than any other AC motors. In addition, there is no slip frequency between the stator and rotor for the SynRM as it is with the induction motor. Moreover, Vector control of SynRM not only can achieve fast dynamic response with less complexity and parameter-independent controller, but also can prevent demagnetization of the motor and allow

*Corresponding Author's E-mail: mona.moussa@yahoo.com

maximum efficiency operation. In this type of motor rotor position determination is essential to synchronize the stator current vector with rotor position but speed sensors increase the cost and the size, and decrease the reliability. Therefore recently many researches were carried out on sensorless control of SynRM (Tamamura et al., 2000; Hanamoto et al., 2004; Chen et al., 2004). These methods can be divided into two types. One uses difference signals of currents or voltages (Jovanovic et al., 1998; Lin and Liu, 2000) or their high-frequency signals to estimate rotor position (Ha et al., 1999; Kang et al., 1999). These methods are generally used in low-speed ranges (Lovell et al., 2002; Lin and Liu, 2000), because the estimation accuracy is independent of the rotor velocity. Further, some methods of this type do not require motor parameters to estimate rotor position and are not affected by parameter variation (Ichikawa et al., 2004). Since this type has some disadvantages such as efficiency and torque ripples, it is not used in middle- or high-speed ranges. The other methods use a fundamental component of voltages or currents to estimate rotor position (Consoli et al., 2000; Capecchi et al., 2001). These methods are used in middle- or high-speed ranges because the amplitude of voltages is large enough. However, these methods must use motor parameters to estimate rotor position, and precise values of motor parameters are required to realize precise position estimation. In SynRMs, the stator inductance and resistance are varied by large current, in particular, the inductance variation caused by magnetic saturation is large. Since these deviations hinder the accuracy of position estimation, sensorless control methods in middle- or high-speed ranges must take this phenomenon into account. Several methods have dealt with the inductance variation: Some methods use a table of inductance parameters [20-22], others use a mathematical model to consider the mutual inductance between the d-axis and the q-axis (Capecchi et al., 2001), and still other methods apply an inductance model to represent the inductance variation (Lovell et al., 2002). In order to realize these methods, it is necessary to measure these parameters across all driving ranges. Since the measurement is complicated and difficult, it is desired that varying parameters are identified in sensorless control. To solve these problems, an effective and simple online parameter identification method to the armature resistance and the quadrature-axis inductance is proposed and then applied to the sensorless control scheme based on the extended EMF. This proposed method is based on a mathematical model taking into consideration magnetic saturation, with the fact that the d-axis inductance can be considered almost constant in practice. Therefore, a reduced order system model of the SynRM is concluded. This reduced system is of first order which can be easily implemented with less hardware. The mathematical model of the SynRM using the EEMF in the rotating reference frame is utilized to estimate both rotor position

and speed. The estimation position error is obtained from the EEMF by a lower-order observer. This scheme corrects the estimated position and speed so that the estimation position error becomes zero. In addition, the method can use any signal that satisfies the condition of persistent excitation. Consequently, using the online parameter identification method, sensorless control can be realized without any prior measurement in situations involving large parameter variations. The paper is organized as follows: section II is a survey. Section III an EEMF model of SynRM using a lower-order observer, taking into consideration magnetic saturation, is derived. An online parameter identification method for position estimation is proposed in section IV. Simulation results of the proposed identification method are demonstrated in section V. The feasibility of the proposed sensorless control method along with parameter identification is verified in section VI. Finally, section VII presents conclusion of the paper.

Survey

Several rotor position estimating techniques have been developed to achieve sensorless synchronous reluctance drives (Capecchi et al., 2001), ((Consoli et al., 2007; Ichikawa et al., 2006; Ciufu and Platt, 2003; Caporal and Pacas, 2008; Chen et al., 2004)). For example, Consoli et al. injected a small high-frequency sinusoidal voltage into the stator windings and then detected the relative high-frequency current derivations (Kang et al., 1999; Consoli et al., 2007). Ichikawa et al. used an extended electromotive force model to estimate the rotor position for SynRMs (Ichikawa et al., 2006). Capecchi et al. and Lagerquist et al. investigated using an extended flux observer to estimate the rotor position for SynRMs (Capecchi et al., 2001; Lagerquist et al., 1994). However, only stator voltage and stator resistance voltage drop are used to compute flux. An offset problem, which may cause estimating error, thus appears. Recently, many researchers have proposed the current-derivation detection method to estimate the rotor position for SynRMs (Ciufu and Platt, 2003; Caporal and Pacas, 2008). In addition, Matsuo and Lipo measured the stator current deviation to estimate the rotor position for SynRMs (Matsuo and Lipo, 1995). This method, however, did not consider the influence of the back EMF of the motor. As a result, only a low-speed operating range or zero speed can be applied. To solve the difficulty, Chen et al. proposed an improved method to compensate for the influence of the back EMF; as a result, a wide adjustable speed control can be obtained (Chen et al., 2004). On the other hand, in order to improve the dynamic performance of an SynRM drive system, several advanced controllers have been developed. For instance, Lin and Liu proposed a robust controller for a position control system of an SynRM (Lin

and Liu, 2001). Shyu et al. studied an optimal position controller of an SynRM via totally invariant variable structure control (Shyu et al., 2000). Zarchi et al. used an adaptive input–output feedback-linearisation-based controller for a sensorless SynRM drive system (Zarchi et al., 2010). Caporal and Pacas investigated a predictive controller for an SynRM taking into account the magnetic cross saturation (Caporal and Pacas, 2007). Liu and Lin proposed a fuzzy sliding-mode controller design for an SynRM drive to improve its dynamic responses (Liu and Lin, 1996). Shyu et al. presented a totally invariant state feedback position controller for an SynRM control system (Shyu et al., 2001). Liu and Hsu proposed an adaptive controller design for an SynRM drive system with direct torque control (Liu et al., 2006). In addition, Liu et al. presented a non-linear controller for an SynRM drive system with reduced switching frequency. From the practical viewpoint, the physical interpretation is an important issue for the controller design of a motor drive system. Recently, passivity-based controller has been developed. The passivity-based controller design has a strong relationship with the physics behaviour of the systems (Wang and Chen, 2001; Wang and Chen, 2005; Gokdere and Simaan, 1997; Cecati, 2000).

Estimation of the machine phase resistance at room temperature is simple and straightforward. The estimation of the machine flux linkages is difficult, especially for machines operating into deep saturation. In such machines, in addition to the saturation effect for the self-axis current, significant cross-saturation effect might be present. Moreover, the presence of harmonics, the space and the switching harmonics, complicates the parameter extraction method. Several methods have been presented in the literature for the estimation of the machine parameters of a wound-field synchronous motor under dynamic condition. The standard method for estimating the parameters of the synchronous machine is the standstill frequency-response (SSFR) method (Vagati et al., 1997). Standstill time-domain methods are also presented to obtain the machine parameters (Chalmers and Musaba, 1998).

The time-domain standstill method was later extended to estimate the machine parameters, including the damper winding parameters, of a permanent magnet synchronous motor (Tamamura et al., 2000). This method also neglects the effect of saturation and cross saturation.

Stumberger et al. (Stumberger et al., 2003) have presented a locked rotor technique where he applies voltage pulses in one axis (e.g., axis) while current in the other axis (e.g., axis) is maintained constant and vice versa. From the sampled voltages and currents, they estimated the machine parameters including saturation and cross-coupling effects. Kilthau et al. (Kilthau and Pacas, 2002) have presented another technique where they used two dc sources to apply current to the two control axes. From the measured current and voltages,

they then estimated the machine parameters. Kilthau et al method requires two voltage sources. Moreover, the voltages are applied at zero speed and at steady state. Therefore, the measured voltages are small in magnitude and may be subject to significant measurement errors. This method also disregards the presence of space harmonics in the voltage waveform. Vagati et al. (Franceschini et al., 2000) have presented another technique to estimate the machine parameters where they have tried to eliminate the effect of stator resistance from the measurement.

Mathematical models of synrms

Definition of Coordinates and Symbols

The coordinates used in this paper are defined in Fig. 1. The $\alpha\beta$ -frame, the dq - frame, and the $\gamma\delta$ - frame are defined as a stationary reference frame, a rotating reference frame, and an estimated rotating reference frame, respectively. The symbols used in this paper are defined as follows:

$$[1] = \begin{bmatrix} 1 & 0 \\ 0 & 1 \end{bmatrix}, \quad [1] = \begin{bmatrix} 0 & -1 \\ 1 & 0 \end{bmatrix} \quad (1)$$

$$\begin{aligned} Q(\theta_e) &= \begin{bmatrix} \cos 2\theta_e & \sin 2\theta_e \\ \sin 2\theta_e & -\cos 2\theta_e \end{bmatrix} \\ S(\theta_e) &= \begin{bmatrix} -\sin 2\theta_e & \cos 2\theta_e \\ \cos 2\theta_e & \sin 2\theta_e \end{bmatrix} \end{aligned} \quad (2)$$

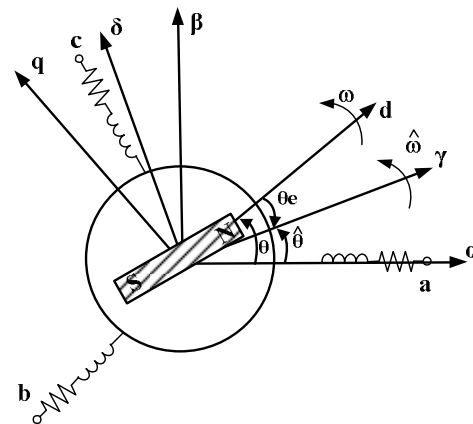

Figure 1. Coordinates of SynRMs.

Extended EMF Model

The mathematical model of the SynRM in the d - q rotating reference frame is given by:

$$\begin{bmatrix} v_d \\ v_q \end{bmatrix} = \begin{bmatrix} R_a + pL_d & -L_q\omega \\ L_d\omega & R_a + pL_q \end{bmatrix} \begin{bmatrix} i_d \\ i_q \end{bmatrix} \quad (3)$$

From the model in the stationary frame, it could be seen that, there are two terms including position information. One is the back EMF term generated by a permanent magnet, and the other is generated by rotor saliency. Thus, position estimation using information on both terms is complicated. To solve this problem, EEMF model is proposed as a mathematical model used in position estimation of synchronous motors. Equation (4) represents the EEMF model that is derived from (3) without approximation.

$$\begin{bmatrix} v_d \\ v_q \end{bmatrix} = \begin{bmatrix} R_a + pL_d & -L_q\omega \\ L_q\omega & R_a + pL_d \end{bmatrix} \begin{bmatrix} i_d \\ i_q \end{bmatrix} + \begin{bmatrix} 0 \\ E_{emf} \end{bmatrix} \quad (4)$$

where, $E_{emf} = \omega[(L_d - L_q)i_q] - (L_d - L_q)(pi_q)$ (5)

The second term of (4) is called an EEMF. Transforming (4) into the γ - δ frame, which lags by θ_e from the d-q reference frame, to get:

$$\begin{bmatrix} v_\gamma \\ v_\delta \end{bmatrix} = \begin{bmatrix} R_a + pL_d & -L_q\omega \\ L_q\omega & R_a + pL_d \end{bmatrix} \begin{bmatrix} i_\gamma \\ i_\delta \end{bmatrix} + \begin{bmatrix} e_\gamma \\ e_\delta \end{bmatrix} \quad (6)$$

where, $\begin{bmatrix} e_\gamma \\ e_\delta \end{bmatrix} = E_{emf} \begin{bmatrix} -\sin\theta_e \\ \cos\theta_e \end{bmatrix} + (\hat{\omega} - \omega)L_d \begin{bmatrix} i_\gamma \\ i_\delta \end{bmatrix}$ (7)

From the model of (6), the state-space equation for estimating the EEMF is obtained when it is assumed that the differentiation of the time of the EEMF is zero.

$$p \begin{bmatrix} i_\gamma \\ e_\gamma \end{bmatrix} = \frac{1}{L_d} \begin{bmatrix} -R_a & -1 \\ 0 & 0 \end{bmatrix} \begin{bmatrix} i_\gamma \\ e_\gamma \end{bmatrix} + \frac{1}{L_d} \begin{bmatrix} 1 \\ 0 \end{bmatrix} v_{\gamma 1} \quad (8)$$

$$p \begin{bmatrix} i_\delta \\ e_\delta \end{bmatrix} = \frac{1}{L_d} \begin{bmatrix} R_a & 1 \\ 0 & 0 \end{bmatrix} \begin{bmatrix} i_\delta \\ e_\delta \end{bmatrix} + \frac{1}{L_d} \begin{bmatrix} 1 \\ 0 \end{bmatrix} v_{\delta 1} \quad (9)$$

Where, $v_{\gamma 1} = v_\gamma + L_q\omega i_\delta$

$$v_{\delta 1} = v_\delta - L_q\omega i_\gamma \quad (10)$$

The input voltages are compensated in order to eliminate the cross coupling between the γ - and δ -axis as shown in (10) and (11). Thus, the state-space equation is decoupled and becomes simple by a least-order observer.

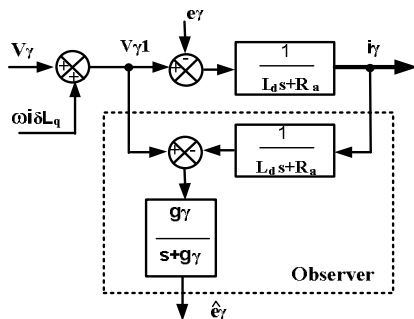

Figure 2. Equivalent block diagram of least-order observer for estimation of EEMF.

Fig. 2 shows the equivalent block diagram of least-order observer for estimating e_γ , where g_γ represents the gain of the observer. Assuming that the error between the estimated speed $\hat{\omega}$ and the actual speed ω is sufficiently

small, the EEMF is estimated as follows:

$$\begin{bmatrix} \hat{e}_\gamma \\ \hat{e}_\delta \end{bmatrix} = E_{emf} \begin{bmatrix} -\sin\hat{\theta}_e \\ \cos\hat{\theta}_e \end{bmatrix} \quad (12)$$

Thus, the estimated position error $\hat{\theta}_e$ can be derived as follows:

$$\hat{\theta}_e = \tan^{-1}\left(-\frac{\hat{e}_\gamma}{\hat{e}_\delta}\right) \quad (13)$$

The estimated speed is compensated by compensator $G_e(s)$ as shown in Fig. 3. The estimated position $\hat{\theta}$ follows the actual one by (14), when the proportional and integral compensator is selected as $G_e(s)$

$$\hat{\theta} = \frac{K_{ep}s + K_{ei}}{s^2 + K_{ep}s + K_{ei}} \theta \quad (14)$$

where, K_{ep} and K_{ei} are proportional and integral gains.

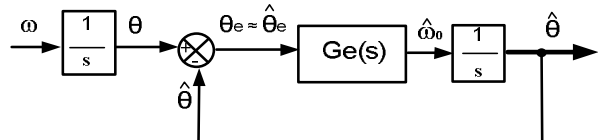

Figure 3. Equivalent block diagram of position and speed estimator.

The transfer function related the actual speed ω to the estimated speed $\hat{\omega}$ is the same as that related θ to $\hat{\theta}$ given by (14). The estimated speed $\hat{\omega}$ is used to motor control and estimation of e.m.f.

Parameter identification based on the system identification theory

The relationship between the d-axis flux ϕ_d and the d-axis stator current i_d of the SynRM is found to be almost linear. Therefore, the d-axis inductance L_d is considered constant. On the other hand, the stator resistance R_a varies practically with motor temperature, and the q-axis inductance L_q varies due to magnetic saturation. These deviations can lead to unreliable estimation of rotor position and speed. That is why; on-line identification of R_a and L_q is essential to enhance the performance of the SRM under any control scheme. For this reason, an identification method is proposed to identify unknown L_q and R_a via a mathematical model using known values such as voltages, currents, and based on the fact that L_d is practically constant.

The unknown coefficients in the model are identified by the proposed parameter identification method, and motor parameters are derived from these coefficients. The mathematical model can be concluded on a stationary reference frame or on an estimated rotating reference frame. In case of parameter identification under rotation conditions, the model on the estimated

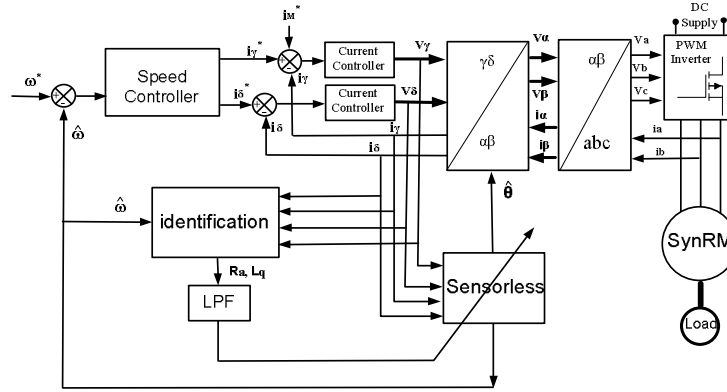

Figure 4. Block diagram of SynRM drive with the proposed on-line parameter identification system.

rotating reference frame is better than on the stationary reference frame because the model coefficients can be almost constant regardless of the rotation conditions (Ichikawa et al., 2004). Thus, the mathematical model of the SynRM in the estimated rotating reference frame is given by transforming this model in the rotating d-q frame to the hypothetical γ - δ frame, and assuming L_d is almost constant:

$$L_d p i_\gamma = v_\gamma - R_a i_\gamma + L_q \omega i_\delta \quad (15)$$

$$L_q p i_\delta = v_\delta - R_a i_\delta - \omega L_d i_\gamma \quad (16)$$

$$L_q p i_\delta = u_\delta - R_a i_\delta \quad (17)$$

$$\text{where, } u_\delta = v_\delta - \omega L_d i_\gamma \quad (18)$$

Therefore, the main idea here is to use the machine equation in the q-axis (δ -axis) to identify the machine parameters R_a and L_q since the term u_δ contains constant parameter L_d . Now, transforming (17) to a discrete state equation:

$$i_\delta(n+1) = A i_\delta(n) + B u_\delta(n) \quad (19)$$

$$\text{where, } A = \left[1 - \frac{R_a \Delta T}{L_q} \right], \quad B = \left[\frac{\Delta T}{L_q} \right] \quad (20)$$

and ΔT is the sampling period. Equation (19) is a first order discrete can be rewritten as:

$$y = \theta z \quad (21)$$

where, θ is the parameter matrix that includes the unknown motor parameters and is given by:

$$\theta = [A \quad B] \quad (22)$$

The scalar y represents the current output, i.e.

$$y = [i_\delta(n+1)] \quad (23)$$

and the vector z contains the past input and output and is given by:

$$z = [i_\delta(n) \quad u_\delta(n)]^T \quad (24)$$

Using the relation of (21), the unknown parameter matrix θ can be derived from known vectors y and z by using the least square method. This method identifies the

parameter matrix $\hat{\theta}$ such that the square of the prediction error reaches minimum [22], i.e. (25) is minimum.

$$c_i = (y - \hat{\theta} z)^2 \quad (25)$$

To identify the parameter matrix $\hat{\theta}$ on-line, a recursive least square 'RLS' method is used [22]. The parameter matrix $\hat{\theta}$ is identified recursively using the following equations:

$$\hat{\theta}(k) = \hat{\theta}(k-1) + (y - \hat{\theta}(k-1)z)z^T P(k) \quad (26)$$

$$P(k) =$$

$$\frac{1}{\lambda} [P(k-1) - P(k-1)z(\lambda + z^T P(k-1)z)^{-1} z^T P(k-1)] \quad (27)$$

where, λ is defined as the weighting coefficient to delete past data. P is a covariance matrix of z . From the calculation of (26) and (27), the parameter matrix θ is identified recursively. This identification method is based only on the relation in (19). Therefore, any band pass filter that separates signals into high frequency components and fundamental ones are not necessary in the system. Thus, the identified motor parameters are derived from the elements of the parameter vector $\hat{\theta}$ as:

$$\hat{L}_q = \frac{B}{\hat{\theta}} \quad (28)$$

$$\hat{R}_a = \frac{(1-A)}{\hat{\theta}} \quad (29)$$

These identified parameters are used in the proposed observer. This identification method can be applied for IPMSMs and SynSMs under magnetic saturation.

The identification system presented in Ichikawa et al., 2006 and Ghaderi and Tsuji, 2006 is based on a second order system of SynRM which is more complex compared to the proposed scheme given by (19), (20) and (21). Therefore, the proposed identification method is simpler and requires less reduced calculations. In addition, the unknown matrix in such case can be rapidly calculated and easily updated.

Simulation results

The simulink block diagram of the proposed on line parameter identification method, based on the reduced

order system of the SynRM using RLS algorithm is shown in Fig. 5, where equations (26) and (27) are updated each step in the identification block, using sampling time $\Delta T=10^{-6}$ sec.

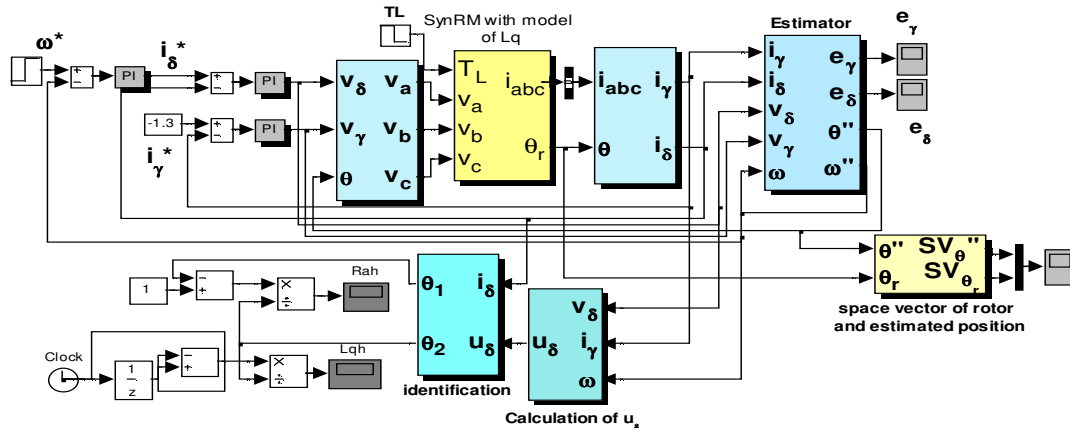

Figure 5. Simulink block diagram of SynRM vector control drive system with the proposed parameter identification scheme

Sensorless control under load variation

Sensorless control with on-line parameter identification was realized using the system shown in Fig. 4. Although the estimation system was based on the EEMF model, the proposed parameter identification system can be applied to any estimation system that uses motor parameters. The block diagram of Fig. 4 consists of three main systems; vector control, sensorless drive control, and proposed parameter identification system. In which, three-phase current signals and voltage references are transformed to two-phase signals on the stationary reference frame, and these signals are transformed to corresponding current and voltage on the estimated rotating reference frame. From these current and voltage signals, motor parameters are identified as in the proposed parameter identification system. Then, it is appropriate for sensorless control to use the identified parameters after they have passed through a low-pass filter because they tend to include fluctuations. The decay time constant of the low-pass filter must be appropriately decided for each parameter. The decay time here was set to 0.02s for the inductance parameter and 0.01s for the resistance parameter. Using these identified parameters, the proposed observer estimates the EEMF, which in turn, estimates the position and velocity. The error between the command speed and the estimated speed is applied to a PI controller to output reference currents. The command γ -axis current which can be considered as an indication of the excitation, is adjusted to 10% of the rated full load current and will remain constant. Then, the injection signal i_M^* is added

to the δ -axis current reference. The error between the command and the measured currents is applied to PI controllers to output the reference voltages.

The ratio of the amplitude of M-sequence signals to the rated current is about 5%, and the frequency of the injection signal i_M^* is about 3 KHz. Of course, it is not necessary to inject this signal when the parameters need not to be identified. Fig. 6 shows the result of the position estimation and parameter identification under load change. The rotational velocity was set to be 157 rad/s.

Although the load condition changed considerably under transient conditions, the position estimation error could be suppressed within less than 0.002s. Accurate position estimation under the condition of varying parameters could be realized by using the identified parameters. The simulation results show the proposed method performs well and speed and angle estimation is correct. Also because motor parameters are identified in a wide range of speed precisely sensorless vector control is achieved at low speed as well as high speed. This ensure the accuracy and the validity of the proposed on line identification method which gives fast identification performance over the whole range of load and speed operation. In such case, motor parameters can be identified on-line; thus, prior parameter measurements for R_a and L_q are not necessary.

It is found that, L_q depends on the q-axis current. Thus, before magnetic saturation, L_q is almost constant. Since $\phi_q = L_q i_q$. Therefore, the average value of the q-axis inductance L_q is found to be 30mH. Whereas, after magnetic saturation, L_q can be modeled as a function of

i_q . The relationship between L_q/i_q is simulated to represent the magnet saturation as shown in Fig. 6(d). Also, it is clear that winding stator resistor value is highly temperature-dependent as shown in Fig. 6(c).

It is clear from the above figures that appropriate motor parameters were identified, and the estimated position coincided exactly with the rotor position. In addition, the estimated speed followed the profile of the

rotor speed accurately, irrespective of load change conditions. Thus, the sensorless SynRM drive system will have adequate performance in order to obtain the necessary position and speed information for replacing a shaft sensor. Moreover, the accuracy of the estimated position which depends on the motor parameters will be improved due to the presence of the identification system that can measure the motor parameters on line.

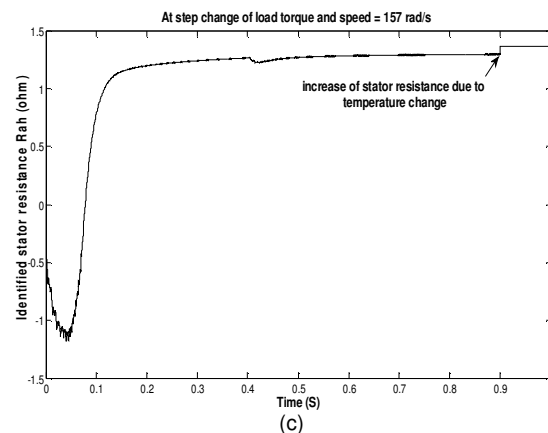
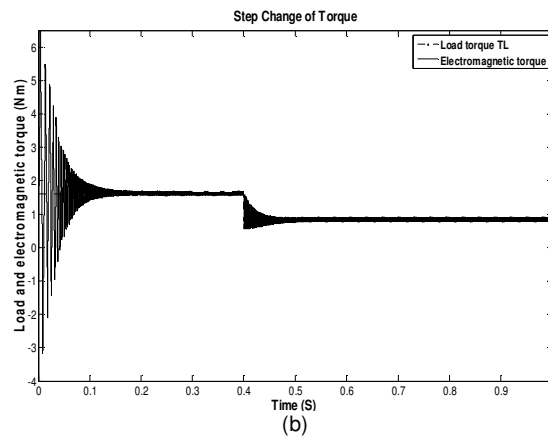
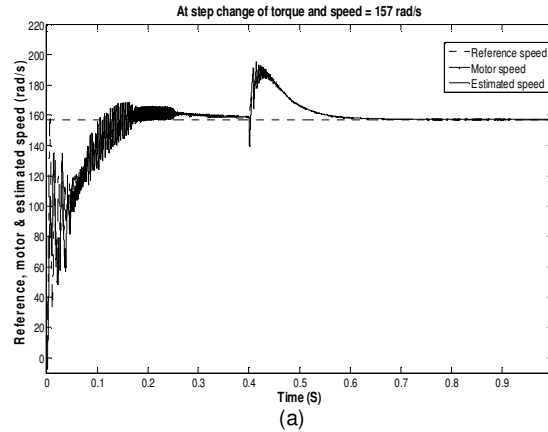

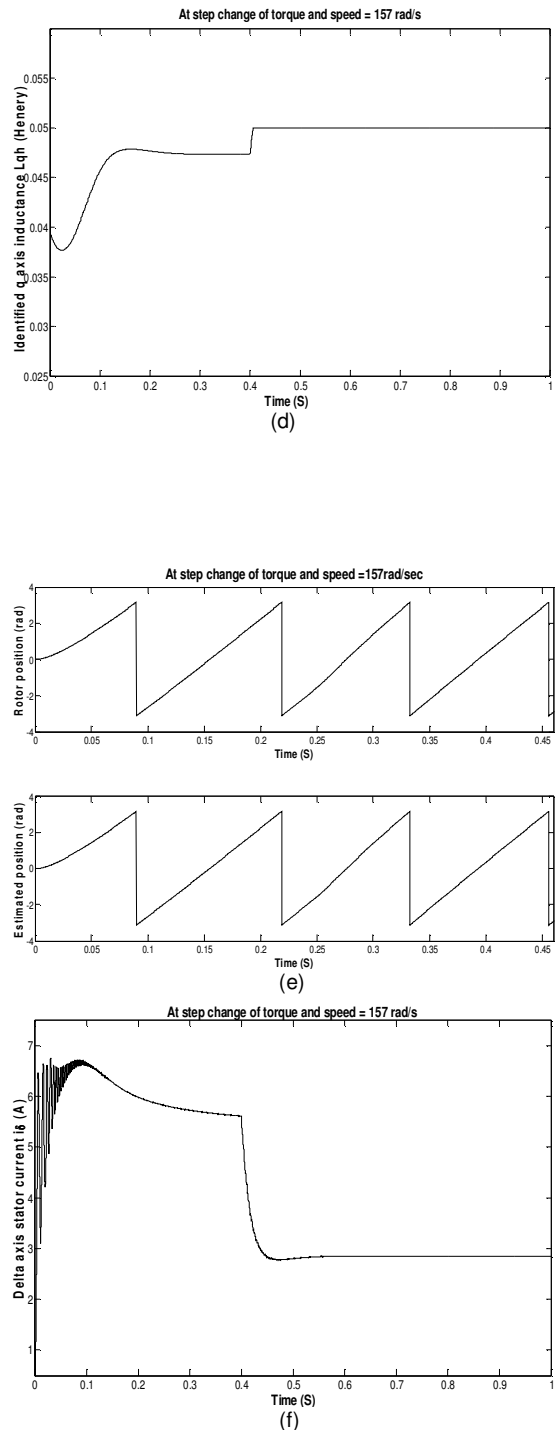

Figure 6. Position estimation and parameter identification error, under load change and speed = 157rad/s.

Therefore, the proposed sensorless drive system with the proposed on-line identification scheme gives fast and accurate transient performance over a wide range of speed and torque operation. It can be noted that, with the use of the identified parameters, position estimation under load change was realized.

CONCLUSION

Several sensorless control schemes have been

proposed. However, most of these methods use motor parameters to estimate rotor position, and hence position estimation error is caused by parameters variations. That is why, motor parameters are identified on-line under sensorless control.

In this paper, the EEMF model, taking into consideration the magnetic saturation, and the sensorless control method based on the EEMF model were presented. Moreover, an online parameter identification method based on a model with saturation was proposed. The

objective of the parameter identification is to identify motor parameters used in position estimation to maintain accuracy of the sensorless control system, since any motor parameter change can generate a position estimation error.

The proposed identification method injects high frequency signals and identifies varying motor parameters on-line; the position estimation system uses these identified parameters to estimate rotor position accurately. The proposed method has several advantages:

Motor parameters can be identified on-line; thus, prior parameter measurements are not necessary.

The proposed method can use any signal that satisfies the condition of persistent excitation and special band pass filter are not necessary.

The proposed method is based on reducing the order of the SynRM model in the hypothetical frame into a first order system which is very simple and easy to be implemented practically with less hardware.

Since in practical case, L_d is maintained constants, and L_q and R_a varied due to magnetic saturation and temperature. The proposed identification system will be used to identify and measure on-line L_q and R_a only. Therefore, the unknown parameter matrix will be simple and can be easily updated compared to the complex unknown parameter matrix proposed (Ichikawa et al., 2006 and Ghaderi and Tsuji, 2006).

Due to the reduced calculation, the proposed identification system requires less hardware to be implemented compared to the other systems proposed (Ichikawa et al., 2006 and Ghaderi and Tsuji, 2006) which use a non-linear model of SynRM.

The simulation results have shown that the proposed on-line identification method can provide fairly good identification performance over a wide range of load conditions and thermal changes. It can also be incorporated into any sensorless speed control scheme. Therefore, with the use of the identification parameters, position estimation under load changes can be realized accurately.

REFERENCES

- Capecchi E, Guglielmi P, Pastorelli M, Vagati A (2001). "Position sensorless control of the transverse-laminated synchronous reluctance motor," IEEE Trans. Ind. Appl. 37(6): 1768–1776.
- Caporal RM, Pacas M (2007). 'A predictive torque control for the synchronous reluctance machine taking into account the magnetic cross saturation', IEEE Trans. Ind. Electron. 54(2): 1161–1167.
- Caporal RM, Pacas M (2008). 'Encoderless predictive direct torque control for synchronous reluctance machines at very low and zero speed', IEEE Trans. Ind. Electron. 55 (12):4408–4416.
- Cecati C (2000). 'Position control of the induction motor using a passivity based controller', IEEE Trans. Ind. Appl. 36(5):1277–1284
- Chalmers BJ, Musaba L (1998). "Design and field-weakening performance of a synchronous reluctance motor with axially laminated rotor", Industry Applications, IEEE Transactions on. 34(5).
- Chen CG, Liu TH, Lin MT, Tai CA (2004) 'Position control of a sensorless synchronous reluctance motor', IEEE Trans. Ind. Electron. 51, (1): 15–25
- Chen CG, Liu TH, Lin MT, Tai CA (2004), "Position control of a sensorless synchronous reluctance motor" IEEE Transactions on Industrial Electronics. 51(1):15-25 .
- Ciufo P, Platt D (2003). 'Sensorless rotor position and speed estimation for a synchronous reluctance motor', IEE Proc. Electr. Power Appl., 150(2): 158–164
- Consoli A, Cavallaro C, Scarcella G, Testa A (2000). "Sensorless torque control of synrel motor drives," IEEE Trans. Power Electron. 15 (1): 28–35
- Consoli A, Scarcella G, Scelba G, Testa A, Triolo DA (2007). 'Sensorless rotor position estimation in synchronous reluctance motors exploiting a flux deviation approach', IEEE Trans. Ind. Appl., 43, (5), pp. 1266–1273
- Franceschini G, Pastorelli M, Scapino F, Vagati A (2000). "Impact of cross saturation in synchronous reluctance motors of the transverse-laminated type," IEEE Trans. Ind. Appl. 36(4):1039–1046.
- Ghaderi TH, Tsuji T (2006) "A novel Implementation of Low Speed Sensorless Vector Control of Synchronous Reluctance Motors with a New Online Parameter Identification Approach," proc of IEEE PEDS-2006. 221-217.
- Gokdere LU, Simaan MA (1997). 'A passivity-based method for induction motor control', IEEE Trans. Ind. Electron., 44, (5), pp. 688–695
- Ha J, Kang SJ, Sul SK (1999), "Position-controlled synchronous reluctance motor without rotational transducer," IEEE Trans. Ind. Appl. 35 (6): 1393–1398.
- Hanamoto T, Ghaderi A, Fukuzawa T, Tsuji T (2004), "Sensorless control of synchronous reluctance motor using modified flux linkage observer with an estimation error correct function," Proc. of the ICEM-2004, Sep, Include CD-ROM.
- Ichikawa S, Tomita M, Doki S, Okuma S (2004). "Initial position estimation and low speed sensorless control of synchronous motors in consideration of magnetic saturation based on system identification theory," in Conf. Rec. IEEE-IAS Annu. Meeting. 971–976.
- Ichikawa S, Tomita M, Doki S, Okuma S (2004). "Sensorless control of synchronous motors based on an extended EMF model and inductance measurement in the model," in Proc. EPE-PEMC, Sep., CD-ROM.
- Ichikawa S, Tomita M, Doki S, Okuma S (2006). 'Sensorless control of synchronous reluctance motors based on extended EMF models considering magnetic saturation with online parameter identification', IEEE Trans. Ind. Appl. 42(5): 1264–1274.
- Jovanovic M, Betz RE, Platt D (1998). "Sensorless vector controller for a synchronous reluctance motor," IEEE Trans. Ind. Appl. 34(2):346–354.
- Jovanovic MG, Betz RE, Jian Y (2002). "The use of doubly fed reluctance machines for large pumps and wind turbines", Industry Applications, IEEE Transactions on. 38(6).
- Kang SJ, Kim JM, Sul SK (1999). 'Position sensorless control of synchronous reluctance motor using high frequency current injection', IEEE Trans. Energy Convers. 14(4): 1271–1275.
- Kang SJ, Kim JM, Sul SK (1999). "Position sensorless control of synchronous reluctance motor using high frequency current injection," IEEE Trans. Energy Convers. 14 (4): 1271–1275.
- Kilthau A, Pacas J (2002) "Appropriate models for the controls of the synchronous reluctance machine," in Proc. IEEE IAS Annu. Meeting. 2289–2295.
- Lagerquist R, Boldea I, Miller TJE (1994). 'Sensorless control of the synchronous reluctance motor', IEEE Trans. Ind. Appl. 30(3): 673–682
- Lin MT, Liu TH (2000). "Sensorless synchronous reluctance drive with standstill starting," IEEE Trans. Aerosp. Electron. Syst. 36(4): 1232–1241.
- Lin MT, Liu TH (2001). 'Design and implementation of a robust controller for a synchronous reluctance drive', IEEE Trans. Aerosp. Electron. Syst. 37(4): 1344–1358
- Lipo T (1991). "Synchronous Reluctance machines- A Viable Alternative for AC Drives?" Electric machines and Power Systems. 19.
- Liu TH, Hsu HH (2007) 'Adaptive controller design for a synchronous reluctance motor drive system with direct torque control', IET Electr.

- Power Appl.1(5): 815–824
- Liu TH, Lin MT (1996). 'A fuzzy sliding-mode controller design for a synchronous reluctance motor drive', IEEE Trans. Aerosp. Electron. Syst. 32(3):1065–1076
- Liu TH, Lin MT, Yang YC (2006). 'Nonlinear control of a synchronous reluctance drive system with reduced switching frequency', IEE Proc. Electr. Power Appl. 153(1):47–56
- Ljung L (1999). System Identification-Theory for the User. Upper Saddle River, NJ: Prentice-Hall.
- Lovelace EC, Jahns TM, Lang JH (2002). "A saturating lumped parameter model for an interior PM synchronous machine," IEEE Trans. Ind. Appl. 38(3): 645–650, May/Jun..
- Matsuo T, Lipo TA (1995). 'Rotor position detection scheme for synchronous reluctance motor based on current measurements', IEEE Trans. Ind. Appl. 31(4): 860–868
- Matsuo T, Lipo TA (1995). "Rotor position detection scheme for synchronous reluctance motor based on current measurements", Industry Applications, IEEE Transactions on. 31(4).
- Morimoto S, Kawamoto K, Sanada M, Takeda Y (2002). "Sensorless control strategy for salient-pole PMSM based on extended EMF in rotating reference frame", IEEE Trans. Ind. Appl. 38(4):1054-1061.
- Saha S, Iijima T, Narazaki K, Honda Y (2000). "High speed sensorless control of synchronous reluctance motor by modulating the flux linkage angle," Proc of IPEC-Tokyo. 643-648.
- Seog-Joo K, Jang-Mok K, Seung- Ki S (1999). " Position Sensorless Control of Synchronous Reluctance Motor Using High Frequency Current Injection" Trans, 14(4).
- Shyu KK, Lai CK, Hung JY (2001). 'Totally invariant state feedback controller for position control of synchronous reluctance motor', IEEE Trans. Ind. Electron. 48 (3):615–624
- Shyu KK, Lai CK, Tai YW (2000). 'Optimal position control of synchronous reluctance motor via totally invariant variable structure control', IEE Proc. Control Theory Appl. 147(1): 28–36
- Stumberger G, Stumberger B, Dolinar D (2003). "Evaluation of saturation and cross magnetization effects in interior permanent magnet synchronous machine," IEEE Trans. Ind. Appl. 39(5): 1264–1271.
- Tamamura T, Honda Y, Morimoto S, Takeda Y (2000). "Synchronous Reluctance motor when used Air-Condition Compressor Motor, a comparative study," Proc. of the IPEC-Tokyo. 654-659.
- Vagati A, Canova A, Chiampi M, Pastorelli M, Repetto M (2000). "Design refinement of synchronous reluctance motors through finite-element analysis", Industry Applications, IEEE Transactions on. 36(4).
- Vagati A, Pastorelli M, Franceschini G (1997). " High-performance control of synchronous reluctance motors", Industry Applications, IEEE Transactions on. 33(4).
- Wang WJ, Chen JY (2005): 'Passivity-based sliding mode position control for induction motor drives', IEEE Trans. Energy Convers. 20(2): 316–321
- WangWJ, Chen JY (2001). 'Compositive adaptive position control of induction motors based on passivity theory', IEEE Trans. Energy Convers. 16(2):180–185
- Zarchi HA, Soltani J, Markadeh GA (2010). 'Adaptive input–output feedback-linearization-based torque control of synchronous reluctance motor without mechanical sensor', IEEE Trans. Ind. Electron. 57(1): 375–384.

NOMENCLATURE

$[v_d v_q]^T$	Voltages on the rotating reference frame.
$[i_d i_q]^T$	Currents on the rotating reference frame.
$[v_\alpha v_\beta]^T$	Voltages on the stationary reference frame.
$[i_\alpha i_\beta]^T$	Currents on the stationary reference frame.
$[e_\alpha e_\beta]^T$	EEMF on the stationary reference frame.
$[v_y v_\delta]^T$	Voltages on the estimated rotating reference frame.
$[i_y i_\delta]^T$	Currents on the estimated rotating reference frame.
R_a	Stator resistance.
L_d	d-axis static inductance.
L_q	q-axis static inductance.
p	Differential operator.
ω	Angular velocity at electrical angle.
	Estimated angular velocity at electrical angle.
θ_e	Rotor position at electrical angle.
	Estimated rotor position at electrical angle.
$\Delta\theta_e$	Position estimation error.
ΔT	Sampling period of identification system.