

Power Transformer Fault Diagnosis using Fuzzy Logic Technique Based on Dissolved Gas Analysis

M. R. Ahmed, M. A. Geliel¹ and A. Khalil

Abstract— the most common fault diagnosis method of power transformer is based on the Dissolved Gas-in-oil Analysis (DGA) of transformer oil. It is a sensitive and reliable technique for the detection of incipient fault condition within oil-immersed transformers. There are a number of methods developed for analyzing these gases and interpreting their significance such as Key Gas, Roger gas ratio, Doernenburg, IEC gas ratio and Duval Triangle. Although DGA has widely been used in the industry, this conventional method fails to diagnosis in some cases. This normally happens for those transformers which have more than one type of fault at the same time [6, 7]. To overcome this limitation, an expert system based on DGA for diagnosis of power transformer condition is proposed in this paper. The proposed technique combines three different DGA methods in one diagnosis scheme in order to overcome the limitation of each method stand alone. The three selected methods are Rogers, IEC and Duval. Moreover, this paper investigates the accuracy and consistency of three methods in interpreting the transformer condition by applying fuzzy logic technique in addition to a new final combined fuzzy system. The evaluation is carried out on DGA test data obtained from different literatures as a test data with size 100 cases. Finally, test was applied on DGA data of utility power transformers of MIDOR Refinery Company located in Alexandria, Egypt.

I. INTRODUCTION

The distribution part in an electrical power system represents 70% of the whole system, while the main part in a distribution system is the power transformers. Therefore, the power transformers are the most important key elements in any power system. It is quite expensive and has no substitute for its major role. It is therefore, very important to monitor the in-service behavior to avoid costly outages and loss of production [6]. Many techniques and tools are developed for power transformers internal faults detection; somehow many of these techniques rely on expert analysis [1].

With the growing demands for reliability, maintainability and survivability in large-scale power plants (PPs) and power systems (PSs), considerable attention has been focused on developing fault diagnosis systems, which includes the detection, isolation, identification or classification of faults, etc [14,15].

Fault diagnosis techniques can be grouped into three categories [14, 15]:

1) Model based techniques; 2) Signal based analysis and processing techniques; 3) Fault diagnosis by artificial intelligence (AI). As shown in Fig. 1.

Here, DGA data was used which can be considered as signal based diagnosis together with fuzzy logic technique (AI), the two grouped methods can be named as a hybrid Approach.

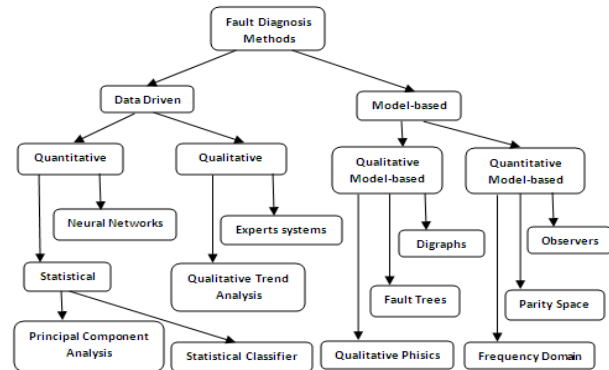

Figure 1. A possible categorization of fault diagnosis [15].

Using fuzzy system in transformer diagnosis is addressed in [18] but it needs more data to obtain good results. Although, there are modern transformer diagnosis techniques like [19] and [20] still, it is important to use classical DGA methods because, oil analysis laboratories depend on these methods to interpret DGA. Therefore, the proposed diagnosis techniques combine the advantages of using Fuzzy system and the classical DGA methods. Since, modern techniques are employed to diagnosis transformers, modern transformer design techniques such that mentioned in [21] and [22] can improve transformer efficiency.

Many devices such as Buchholz relay and Differential relay have been evolved to monitor condition of power transformer. However, they respond only to severe power failure requiring immediate removal of transformer from service. Thus, preventive techniques for early detection of faults to avoid costly outages would be valuable. DGA is considered as one of the best efficient techniques that achieves more serviceability and reliability [7].

In our case (utility transformer), the protection relay fails to detect transient current spikes and earth leakage which are continually repeated during operation. Therefore, a new diagnosis tool to detect faults presence accurately and moreover fault location is very necessary. This work is divided into two parts; the first is DGA diagnosis tool to detect the existence of fault and its type and the second is electrical transformer signal analysis tool to ensure fault presence and locate the fault location within transformer winding. In this paper, DGA diagnosis tool will be discussed and later on the future work, transformer currents signal analysis tool will be covered.

II. FAULT GAS ANALYSIS (DGA)

The main function of mineral oil in transformer is as a cooler of transformer and provides insulation as well. When mineral oil is subjected to high thermal and electrical

¹ Corresponding author, Associate Professor, Arab Academy for Science and Technology (AASST), mostafa.geliel@aast.edu

stresses, it decomposes and as a result, gases are generated. These gases are considered as fault indicators and can be generated in certain patterns and amounts depending on the characteristics of the fault [4].

During transformers operation, the oil acts as a dielectric medium and also as a heat transfer agent. The breakdown of electrical insulating materials and related components inside the transformer liberates gases within the unit. The distribution of these gases can be related to the type of electrical fault, and the rate of gas generation can indicate the severity of the fault [2]. Meanwhile, it is well believed that some particular gases are evolved with decreasing in the heat dissipation ability of insulating oil and paper during faults due to increased electrical stresses. Gases produced due to oil decompositions are hydrogen (H_2), methane (CH_4), acetylene (C_2H_2), ethylene (C_2H_4) and ethane (C_2H_6) and paper decomposition produces carbon monoxide (CO) and carbon dioxide (CO_2). Carbon monoxide (CO) and carbon dioxide (CO_2) are well known for revealing paper degradation related faults, ethylene (C_2H_4) and ethane (C_2H_6) are significant in indication with increased oil temperature, partial discharge being low level energy produces hydrogen (H_2), methane (CH_4), arcing can be identified by observing the evolution of acetylene (C_2H_2), hydrogen (H_2). On the other hand, break down voltage (BDV) insulating of oil plays as an important parameter for determining the dielectric strength of insulating oil and gives a significant indication of oil degradation. So internal catastrophic failures related to thermal faults can be investigated by sub dividing thermal failures as oil thermal faults and paper thermal faults [1]. Similarly electrical related failures can be investigated well by subdividing the faults as PD electrical faults and arcing faults. This is clearly shown in Fig.2 [1].

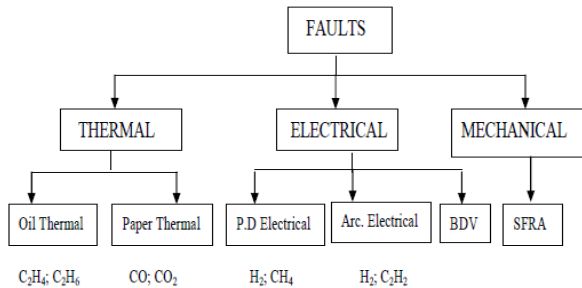

Figure 2. Classification of faults [1].

The conventional DGA diagnostic methods are based on the ratio of gases generated from a single fault or from multiple faults [15]. When gases released from more than one fault in a transformer are collected, the relation between different gases becomes too complicated which may not match the codes predefined. In fact, the gas ratio boundary may not be clear (i.e. ambiguous or fuzzy), especially when more than one type of fault exist. Therefore, between different types of faults, the code should not change sharply across the boundaries [6]. Hence, by applying fuzzy rule based technique, it is possible to distinguish fault in a great variety of oil-filled equipment. Table 1 addressed the fault types in this paper.

Partial discharge, arcing and overheating are the three major causes of fault related gases. The energy dissipation is small in partial discharge, medium in overheating and the highest in arcing [3].

TABLE 1. Fault Type used in Analysis

Fault Type	Fault Type Code
Normal	Normal
Partial Discharge and Corona	PD
Arching	ARC
Thermal fault	TF

III. DGA Interpretation Methods

In this paper, two of the ratio methods were studied: Roger's ratio and IEC ratio. Each diagnosis method was grouped according to the faults type by gas ratio code in addition to previous methods, third method is Duval triangle which depend on three gases (CH_4 , C_2H_2 , C_2H_4) percentage and some gases limits.

A. Roger's ratio

The Roger's ratio method utilizes four gas ratios (CH_4/H_2 , C_2H_6/CH_4 , C_2H_4/C_2H_6 and C_2H_2/C_2H_4). Diagnosis of faults is accomplished with a simple coding scheme as addressed in Table 2 and 3 [12].

TABLE 2. Roger's gases ratio codes [12]

Gas ratio	Ratio code	Code
CH_4/H_2	MH	5-0-1-2
C_2H_6/CH_4	EM	0-1
C_2H_4/C_2H_6	EE	0-1-2
C_2H_2/C_2H_4	AE	0-1-2

TABLE 3. Classification of faults based on Roger's ratio codes [12]

MH	EM	EE	AE	Diagnosis	Abbreviation
0-1-2	0-1	0-1-2	0	Thermal fault	TF
0	0	0-1-2	1-2	Arching	ARC
5	0	0	0-1-2	Partial discharge	PD
0	0	0	0	Normal deterioration	Normal

B. IEC ratio

The IEC ratio is an improvement over the Rogers's method. Instead of using four gas ratios, ratio C_2H_6/CH_4 was dropped because it indicated only a limited temperature range of decomposition [9]. The remaining three gas ratios have different ranges of code compared to Roger's method and their codes are addressed in Table 4 [12]. The fault interpretations can be divided into 4 different types and they are listed in Table 5 [12].

TABLE 4. IEC ratio codes [12]

Ratio code	Code
AE	0-1-2
MH	0-1-2
EE	0-1-2

TABLE 5. Classification of fault based on IEC ratio codes [12]

AE	MH	EE	Diagnosis	Abbreviation
0	0 - 2	0 - 1 - 2	Thermal fault	TF
1 - 2	0	1 - 2	Arcing	ARC
0 - 1	1	0	Partial discharge	PD
0	0	0	Normal	normal

C. Duval triangle

M. Duval developed this method in the 1960s. According to [5], to determine whether a problem presence at least one of the hydrocarbon gases or hydrogen must be at *L1* level or above as shown in Table 6.

TABLE 6. L1 limits of Duval Triangle [5].

Gas	L1 Limits
H ₂	100
CH ₄	75
C ₂ H ₂	3
C ₂ H ₄	75
C ₂ H ₆	75

Once a problem has been determined to exist, to obtain diagnosis, calculate the total accumulated amount of the three Duval Triangle gases (CH₄, C₂H₂, C₂H₄) and divide each gas total to find the percentage of each gas of the total. Plot the percentages of the total on the triangle as shown in Fig.3 to arrive at the diagnosis [5].

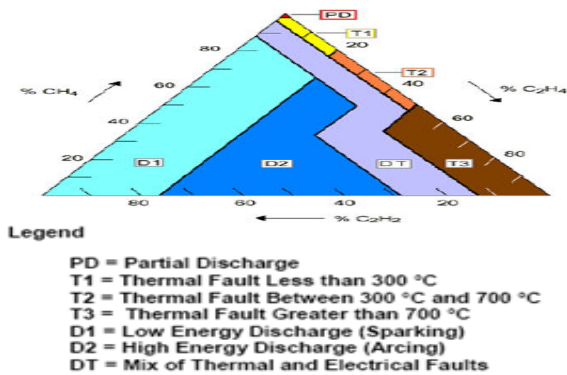

Figure 3. DGA diagnosis with Duval triangle [5]

Although Roger’s ratio and IEC ratio are useful, the drawback of these ratio methods is that there can be some combinations of gases that show a fault but actually do not fit into the gases limits range which is needed for fault presence. Therefore, Duval triangle fill this gap by ensure gases limits before doing diagnosis.

IV. Fuzzy Logic Application

The fuzzy logic analysis consists of three parts:

1. Fuzzification is the process of transforming crisp input values into grades of membership for linguistic terms of fuzzy sets. The membership function is used to associate a grade to each linguistic term.
2. A chosen fuzzy inference system (FIS) is responsible for drawing conclusions from the knowledge-based fuzzy rule set of if-then linguistic statements. Fault types listed in Table 4 and Table 6 form the fuzzy rule set for the diagnosis system.

3. Defuzzification then, converts the fuzzy output values back into crisp output actions [4].

A. Fuzzy Roger’s ratio

As listed in Table 3, the four ratio codes are defined as inputs and classified as either Low (Lo), Medium (Med), High (Hi) and Very High (VH) [10]. Table 7 shows the membership intervals of each ratio.

TABLE 7. Roger fuzzy inputs membership function intervals for gases ratio

Ratio code	Range	Code
MH	$x < 0.1$	5 (Lo)
	$0.1 \leq x \leq 1.0$	0 (Med)
	$1.0 \leq x \leq 3.0$	1 (Hi)
	$x > 3.0$	2 (VH)
EM	$x < 1.0$	0 (Lo)
	$x \geq 1.0$	1 (Hi)
EE	$x < 1.0$	0 (Lo)
	$1.0 \leq x \leq 3.0$	1 (Med)
	$x > 3.0$	2 (Hi)
AE	$x < 0.1$	0 (Lo)
	$0.1 \leq x \leq 3.0$	1 (Med)
	$x > 3.0$	2 (Hi)

The membership boundaries for gases ratio EM, AE, MH and EE are represented by a trapezoidal fuzzy-membership function illustrated in Fig.4 respectively. The membership has no 50% overlap according to the tuning method.

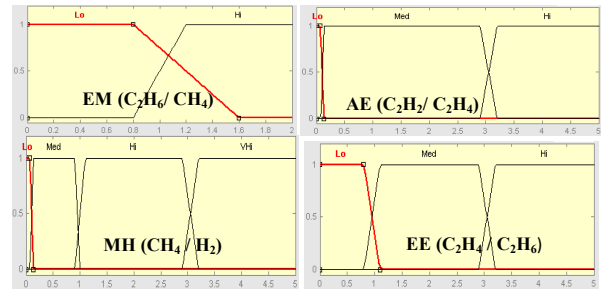

Figure 4. Roger’s fuzzy inputs membership function for gases ratio

Fuzzy inference uses IF-THEN rule-based system, given by, IF antecedent and THEN consequent. Here, 29 fuzzy rules can be derived from the four gas ratios.

When fuzzy rule has multiple antecedents, the fuzzy operator AND for minimization operator and OR for maximization operator is used to obtain a single number that represents the result of the antecedent evaluation.

Although the fuzzy rules appear strictly defined, borderline cases with gas ratio on or near the line between linguistic values (low, medium, high and very high) allows FIS to interpret membership of these rules flexibly and classify these cases under two different fault types with individual probability of occurrence attached to each type [11].

B. Fuzzy IEC ratio

The three gas ratio codes are defined as inputs and classified as either Low (Lo), Medium (Med) and High (Hi) according to membership intervals as tabulated in Table 8 and is the fuzzy inputs membership function for this method is shown in Fig. 5. 20 fuzzy rules can be defined based on the fault types listed in Table 8. The fuzzy analysis of this method was developed using the same technique as described in the previous method

C. Fuzzy Duval triangle

Duval method has three gases percentage (as listed in Table 9.) are converted into fuzzy logic controller with three inputs each input divided into memberships as needed to achieve the method rules and one output with four memberships represent fault types. But, there is another part of Duval triangle must be achieved which represents gases normal limits. Therefore, another fuzzy controller will be added to represent gases normal limits.

TABLE 8. IEC fuzzy inputs membership function intervals for gases ratio

Ratio code	Range	Code
AE	$x < 0.1$	0 (Lo)
	$0.1 \leq x \leq 3.0$	1 (Med)
	$x > 3.0$	2 (Hi)
MH	$x < 0.1$	1 (Lo)
	$0.1 \leq x \leq 1.0$	0 (Med)
	$x > 1.0$	2 (Hi)
EE	$x < 1.0$	0 (Lo)
	$1.0 \leq x \leq 3.0$	1 (Med)
	$x > 3.0$	2 (Hi)

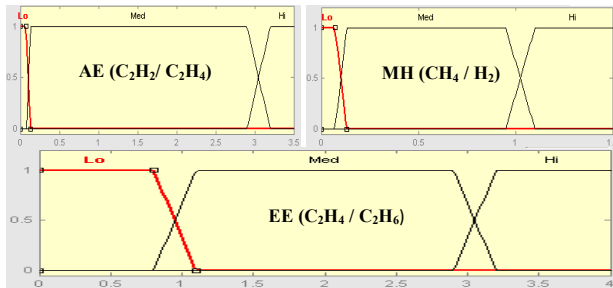

Figure 5. IEC fuzzy inputs membership function for gases ratio

TABLE 9. Duval triangle zone limits

PD	98 % CH ₄	100 % CH ₄		
D1 (ARC)	23 % C ₂ H ₄	13 % C ₂ H ₂	100 % C ₂ H ₂	
D2 (ARC)	23 % C ₂ H ₄	13 % C ₂ H ₂	38 % C ₂ H ₄	29 % C ₂ H ₂
T1 (TF)	4 % C ₂ H ₂	10 % C ₂ H ₄		
T2 (TF)	4 % C ₂ H ₂	10 % C ₂ H ₄		
T3 (TF)	15 % C ₂ H ₂	50 % C ₂ H ₄	100 % C ₂ H ₄	

Fuzzy Duval triangle inference system is consists of 3 linguistic variables are the three relative percentages: % CH₄, % C₂H₂ and % C₂H₄ with 4 linguistic values: very low, low, medium and high and 1 set of reference: $U = [0, 100]$ for every linguistic variable which has trapezoidal membership function as shown in Fig.6.

D. New proposed fuzzy system

Each of the above three methods of fault detection have advantages and limitations. To enhance the advantages and reduce the limitations a new proposal is introduced. The proposed system is achieved by building a new fuzzy logic controller consists of the three fuzzy logic controllers of three methods combined together to get more high accuracy in addition to normal gases limits fuzzy logic controller which is a part of Duval triangle method.

The new fuzzy system technique is consists of three stages: first stage represents that each of three fuzzy methods manipulates five gases as inputs to deliver its own

fault type result, the second stage consists of a grouping fuzzy controller that has three inputs which are three faults type results of three fuzzy methods then the output of grouping fuzzy controller is also a fault type result, but this is after obtain better result from three fuzzy methods, in the same time there is a fuzzy controller called normal limits has five inputs which are the five gases concentration values to deliver only one output represents gases normal limitation and finally, the third stage contains two fuzzy controllers: grouping fuzzy controller and normal limit fuzzy controller as mentioned above where, the output of pervious two fuzzy controllers are being the inputs of the new fuzzy system to handle the final fault type result of power transformer.

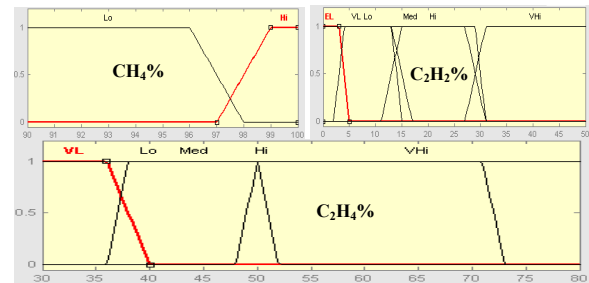

Figure 6. Duval fuzzy inputs with trapezoidal membership functions for gases ratio codes CH₄%, C₂H₂% and C₂H₄%.

As shown in Fig.7, the new system fuzzy logic technique has two inputs: normal limit fuzzy controller and grouping fuzzy controller.

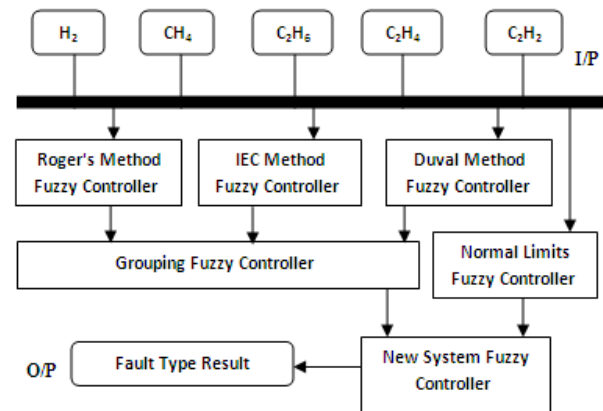

Figure 7. New fuzzy system technique block diagram.

First input of new system fuzzy controller is the output of gases normal limits fuzzy controller which has five inputs represent the five gases (H₂, CH₄, C₂H₆, C₂H₄, and C₂H₂) concentration value in ppm and each input has two triangle memberships (high and low) to achieve gas normal limit, gases normal limits fuzzy controller has one output which has two triangle memberships which represent Normal and Fault as shown in Fig.8.

The second input of new system fuzzy controller is the output of the grouping fuzzy controller which has three inputs which represent outputs of the three fuzzy methods controllers (Roger, IEC and Duval).

Each of the three inputs of the grouping fuzzy controller has four trapezoidal memberships function and one output which has four triangle memberships function as shown in Fig.9.

The new fuzzy system controller has two inputs and one output. As mentioned above, the two inputs are named normal limits and grouping. The normal limit input has two triangle memberships function: normal and fault, and the second input has four triangle memberships function. The only one output has four triangle memberships function as shown in Fig.10.

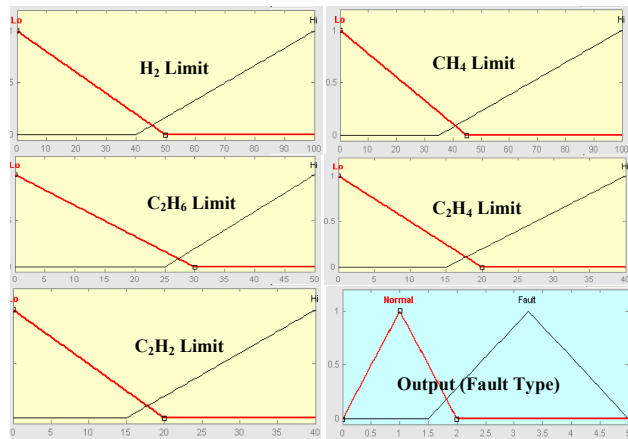

Figure 8. Normal limits fuzzy controller inputs and output membership; five gases (H_2 , CH_4 , C_2H_6 , C_2H_4 and C_2H_2) and one output define its limits.

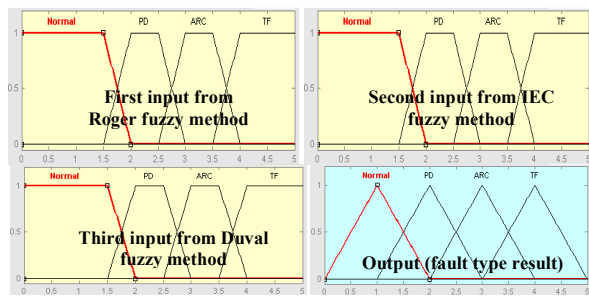

Figure 9. Grouping fuzzy controller three inputs and one output membership function.

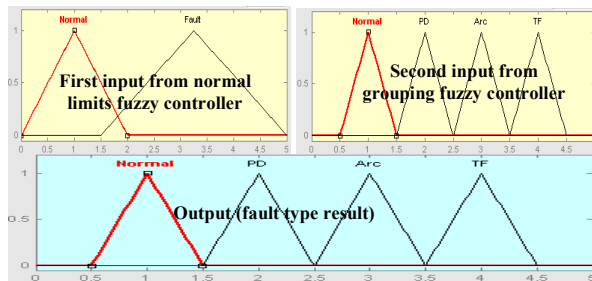

Figure 10. New fuzzy system controller two inputs and one output membership functions.

V. Results and Discussion

In order to evaluate the performance of fuzzy logic controllers to classify the fault types of the power transformer, 100 oil samples, as DGA data test which is collected from real measurement data, were used. A comparison of results for the three individual fuzzy methods and final new fuzzy system is listed in Table 10.

Table 11 shows accuracy for each of three fuzzy methods alone, fuzzy Roger's ratio, fuzzy IEC ratio and fuzzy Duval compared to the new fuzzy logic system. By examine Table 11, it was found that the fuzzy Roger's ratio

made correct diagnosis in 84 samples out of 100 while, it has 15 samples as false alarm but it could not detect one sample. Fuzzy IEC ratio can correctly diagnose 84 samples of the 100 samples while, it has 16 samples as false alarm. Fuzzy Duval defined 72 of the 100 samples while, it has 28 samples as false alarm. Finally new fuzzy logic system made correct 89 samples of the 100 samples while, it has only 11 samples as false alarm.

As it shown from Table 11, the final new fuzzy system has the highest accuracy. From the results obtained, it is proved that by applying the fuzzy logic system, the incipient fault can be defined and classified effectively. Table 11 and Fig. 11 illustrate all DGA test data and its associated actual fault type compared with fault type result of three fuzzy methods individual and final new fuzzy system.

TABLE 10. Three individual methods fuzzy logic controller and final new fuzzy technique comparison.

	Roger	IEC	Duval	Combined
Non-detectable	1	0	0	0
False alarm	15	16	28	11
Accuracy	84%	84%	72%	89%

TABLE 11. DGA test Data and four fuzzy controller results statistics.

	Actual Fault	Roger	IEC	Duval	New System
Normal	12	2	1	0	7
P.D	12	9	11	1	10
ARC	33	33	32	30	32
T.F	43	41	40	42	40

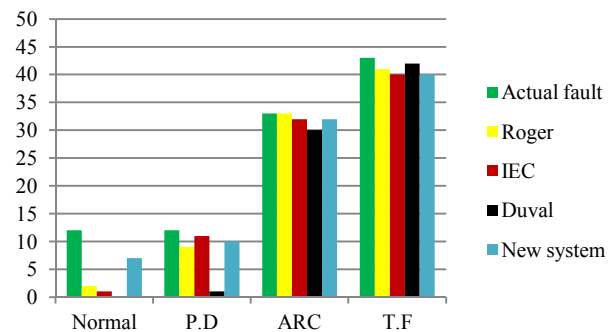

Figure 11. The three methods and new system statistics comparison.

The utility transformers characteristics are summarized in Table 12 and their DGA data analysis are addressed in Table 13. The data of DGA result report delivered from gas chromatography lab. of Egyptian electricity holding company is associated with three individual fuzzy methods and new fuzzy system fault type results.

As listed in Table 14, the DGA report is using classical Duval method and its result is same as Fuzzy Duval logic result which is TF (thermal fault) but, the two individual fuzzy methods (Roger and IEC) show different result (PD) which is partial discharge and also the final new fuzzy

technique because the last two methods are very sensitive with PD faults more than Duval method while, all fuzzy methods together with new fuzzy system ensure that there is an existing fault. It has been proved to be a very useful tool for transformer diagnosis.

TABLE 12. Utility transformers characteristics

No	1	2
Apparent power "S" (MVA)	2.5	2
Operating voltage "V" (KV)	6.6/0.4	6.6/0.4

TABLE 13. Utility transformers DGA data and associated fault type results

TR. No	H ₂ (ppm)	CH ₄ (ppm)	C ₂ H ₆ (ppm)	C ₂ H ₄ (ppm)	C ₂ H ₂ (ppm)	DGA Report (Duval)	Roger	IEC	Duval	Combined new system
1	260	3	18	2	0	TF	PD	PD	TF	PD
2(a)	586	19	77	6	0	TF	PD	PD	TF	PD
2(b)	574	4	27	3	0	TF	PD	PD	TF	PD

VI. Conclusion & Future Work

In this paper, three methods have been applied for the interpretation of fault types from the DGA data namely Roger's ratio, IEC ratio and Duval triangle. Fuzzy logic was explored to improve the diagnosis technique. It has been proven that by using fuzzy logic, the fault type of transformer can be obtained efficiently. Fuzzy logic is applied as the practical representation of the relationship between the fault type and the dissolved gas levels with fuzzy membership functions. By applying fuzzy logic with DGA methods, the lifespan of transformer can be increased while the cost of maintenance can be reduced accordingly. In order to increase the accuracy of these methods, a new fuzzy logic system was built, which is a combination of three fuzzy methods. These three methods are combined into a new fuzzy logic structure to increase accuracy and results show increased accuracy of new fuzzy technique compared to individual method alone. All the three methods have different lower accuracy but when combined together give high accuracy through new fuzzy logic system. The designed expert system has been tested for 100 different cases of transformer gas ratio records which show its effectiveness in transformer diagnosis.

It was found out that the new fuzzy system discussed in this paper uses fewer data to get better result employed three standard methods by fuzzy technique compared with the approach explained in paper [18] this gives advantage that with some available data we obtain better result and prediction is being more precise.

This work is a part of complete transformer fault diagnosis by detecting fault type and location, the other part will be completed later using transformer electrical signal analysis.

REFERENCES

[1]. U. M. Rao and D. V. Kumar, "A Novel technique to precise the diagnosis of power transformer internal faults," *International Journal of Electrical and Electronics Engineering*, vol. 1, iss. 3, 2012, pp. 1-5.

[2]. N. A. Muhamad, B. T. Phung and T. R. Blackburn, K. X. Lai, "Comparative study and analysis of DGA methods for transformer mineral oil," *PowerTech, IEEE Lausanne*, pp.45-50, 15 July 2007.

[3]. B. Németh, S. Laboncz and I. Kiss, "Condition monitoring of power transformers using DGA and fuzzy logic," *IEEE Electrical Insulation Conference, Montreal, QC, Canada*, pp.373-376, 31 May-3 June 2009.

[4]. R. N. Afifah, I. Musirin, D. Johari, M. M. Othman, T. K. A. Rahman and Z. Othman, "Fuzzy logic application in DGA methods to classify fault type in power transformer," *International Conference on Electric Power Systems, High voltages, Electric machines, International conference on Remote sensing - Proceedings*, 2010, pp.83-88.

[5]. "Transformer Diagnostics", *Facilities Instructions, Standards and Techniques, Hydroelectric Research and Technical Services Group, Bureau of Reclamation, Denver, U.S. Dept. of Interior, CO*, vol. 3, no. 31, pp. 5-13, June 2003.

[6]. A. A. Albakry, "Modified fault diagnosis method for power transformers using fuzzy logic technique," *Journal of Babylon University, Pure and Applied Sciences*, vol.19, no.2, 2011, pp.753-764.

[7]. N. K. Dhote and S. B. Bodkhe, "Proposal for an improvement in transformer diagnosis by DGA using expert system," *Australasian Universities Power Engineering Conference*, Brisbane, Australia, 26-29 September 2004.

[8]. G. David and M. Rajaram, "Prediction of faults using hydrocarbon gases data of mineral oil immersed power transformers using computer intelligence," *Journal of Asian Scientific Research*, vol.2, no.1, 2011, pp.6-13.

[9]. N. A. Muhamad, B. T. Phung, and T. R. Blackburn, "Fuzzy logic application in evaluation of DGA interpretation methods", *International Journal of Power, Energy and Artificial Intelligence*, vol. 2, no. 1, pp. 117- 123, March 2009.

[10]. Q. Su, L. L. Lai and P. Austin, "A fuzzy dissolved gas analysis method for the diagnosis of multiple incipient faults in a transformer," *IEEE Transactions on Power Systems*, vol. 15, no. 2, pp. 593-598, May 2000.

[11]. C. Chang, C. Lim, and Q. Su, "Fuzzy-neural approach for dissolved gas analysis of power transformer incipient faults", *Australian Universities Power Engineering Conference*, Brisbane, Australia, 26-29 September, 2004.

[12]. D. V. S. S. Siva and G. N. S. Kalyani, "ANN approach for condition monitoring of power transformers using DGA," *TENCON, IEEE Region 10 Conference*, pp. 444-447, 2004.

[13]. H. Ma, Z. Li, and P. Ju, "Diagnosis of power transformer faults based on fuzzy three-ratio method," *7th International Power Engineering Conference*, 2005.

[14]. P. Pareti, *Mining unexpected behaviour from equipment measurements*. Uppsala University, Disciplinary Domain of Science and Technology, Mathematics and Computer Science, Department of Information Technology, Student thesis, 2010.

[15]. J. J. Dukaram, "Transformer oil diagnosis using fuzzy logic and neural networks," *Electrical and Computer Engineering Canadian Conference*, vol. 1, pp.329-332, 14-17 September 1993.

[16]. Wan, Y. How and M. Khalid, "Transformer fault diagnosis using fuzzy logic interpretations," *Conference Proceeding of Instrument Asia99*, Technical Symposium. Singapore, 1999.

[17]. D. V. S. S. Siva and G. N. S. Kalyani, "Application of AI techniques for non-destructive evaluation of power transformers using DGA," *International Journal of Innovations in Energy Systems and Power*, vol. 2, no. 1, pp 37-43, June 2007.

[18]. N. Pamuk and Y. Uyaroglu, "The analysis of electrical and mechanical faults in power transformers by Fuzzy expert system," *Scientific Research and Essays*, vol. 5, no. 24, pp. 4018-4027, 18 December 2010.

[19]. P.S. Georgilakis, J.A. Katsigiannis, K.P. Valavanis, A.T. Souflaris, "A systematic stochastic petri net based methodology for transformer fault diagnosis and repair actions," *Journal of Intelligent and Robotic Systems*, vol. 45, No. 2, pp. 181-201, Feb. 2006.

[20]. P.S. Georgilakis, "Condition monitoring and assessment of power transformers using computational intelligence," *International Journal of Electrical Power and Energy Systems*, Vol.33, No.10, pp.1784-1785, Dec. 2011.

[21]. P.S. Georgilakis, *Spotlight on modern transformer design*. Springer, London, UK, 2009.

[22]. P.S. Georgilakis, M.A. Tsili, A.T. Souflaris, "A heuristic solution to the transformer manufacturing cost optimization problem," *Journal of Materials Processing Technology*, Vol.181, No.1-3, pp.260-266, Jan. 2007.